

THE MINNESOTA GRAND MASTER 2

Set up and Operation Manual

Your Machine Serial Number: _____



1005 17th Street
Columbus, NE 68601
Service Dept. 1-800-795-8251
serv@technikmfg.com

THE GRANDMASTER 2
MINNESOTA
OPERATION MANUAL
TABLE OF CONTENTS

SAFETY	2
UNPACKING	2
MACHINE DIAGRAM	3
MACHINE MOUNTING	3
START-UP	4
AUTOMATIC SEQUENCING	4
RANDOM / NON-RANDOM MODE	4
SERVICE MODE	4
RUN MOTOR	4
OPERATING MODE SUMMARY	5-6
INSTALLING PUSHBUTTONS	7
COLUMN PRICING	8
RANDOM COLUMN SET UP CHART	8
CARD THICKNESS ADJUSTMENT	9
LOADING CARDS / UNLOADING CARDS	10 - 11
CHECKING CARD AND MONEY COUNT	12
NON - RESETTABLE COUNTS	12
RESETTING COUNTS	13
OPENING/CLOSING RECORDS (CASH DOOR)	13
OPENING/CLOSING RECORDS (PRODUCT DOOR)	13
POWER OFF/ON RECORDS	14
RE-INITIALIZATION PROCEDURE	14
TROUBLESHOOTING	
ERROR CODES	15 - 16
ERROR CODE FLOW CHARTS	17 - 24
CARD JAM OR HESITATE	25
CARDS JAMMING FLOW CHART	25
ODD COUNTS AND DISPENSING	26
CARD NOT DISPENSING FLOW CHART	26
FUSE BLOWN	27
NO POWER	27
POWER INTERRUPTIONS	27
NO POWER FLOW CHART	28
CALLING A SERVICE TECHNICIAN	29
SERIAL NUMBER LOCATIONS	29
REGULAR MAINTENANCE (SERVICE DOOR REMOVAL)	29
CONTROL BOARD	30
BILL ACCEPTOR PROBLEMS	31
COIN MECHANISM	31
PYRAMID BILL ACCEPTOR	32 - 36
RAMDOMIZER KEY INSTRUCTIONS	
SERVICE LOG SHEET	37
ACCOUNTING SHEET	38

SAFETY CONSIDERATIONS

1. Unplug the machine when servicing – failure to do this could cause serious injury.
2. If the power cord is damaged, the manufacturer, its service agent, or a similarly qualified person must replace it.
3. Permanent bypass of any safety switches may cause serious injury.
4. Refer to the “**Machine Mounting**” section of the manual for proper installation instructions.
5. A three-prong grounded outlet must be used to power this machine.
6. Do not overload power circuits.
7. Do not use extension cords to run power to this machine.

UNPACKING

When a machine is received, it should be carefully unpacked and checked closely for any possible damage. If a freight company is involved and there is some damage, they should be notified immediately. The machine should **NOT** be installed until such time as the freight company inspects it and can make out their report.

Please remove and save packing materials for later use.

The following items should be packed in the carton:

<u>QUANTITY</u>	<u>DESCRIPTION</u>
1	8 -COLUMN PULL-TAB VENDING MACHINE
1	Fuse – 6 ¼ AMP
8	Short Weights
8	Three Tab Adaptors
8	Inside White Pushbutton Backs
8	Clear Pushbutton Covers
8	Pushbutton labels - \$.25
8	Pushbutton labels - \$.50
8	Pushbutton labels - \$1.00
8	Pushbutton labels - \$2.00
1	Machine Manual
4	Machine Keys - 4 for each door
1	Hex Wrench (For Adjustment Procedure)
1	Card Hook
1	Card Display Holder
1	Warranty certificate

*If the machine is equipped with a modem, an alarm, or a printer an Options Manual will be included as well.

MACHINE DIAGRAM

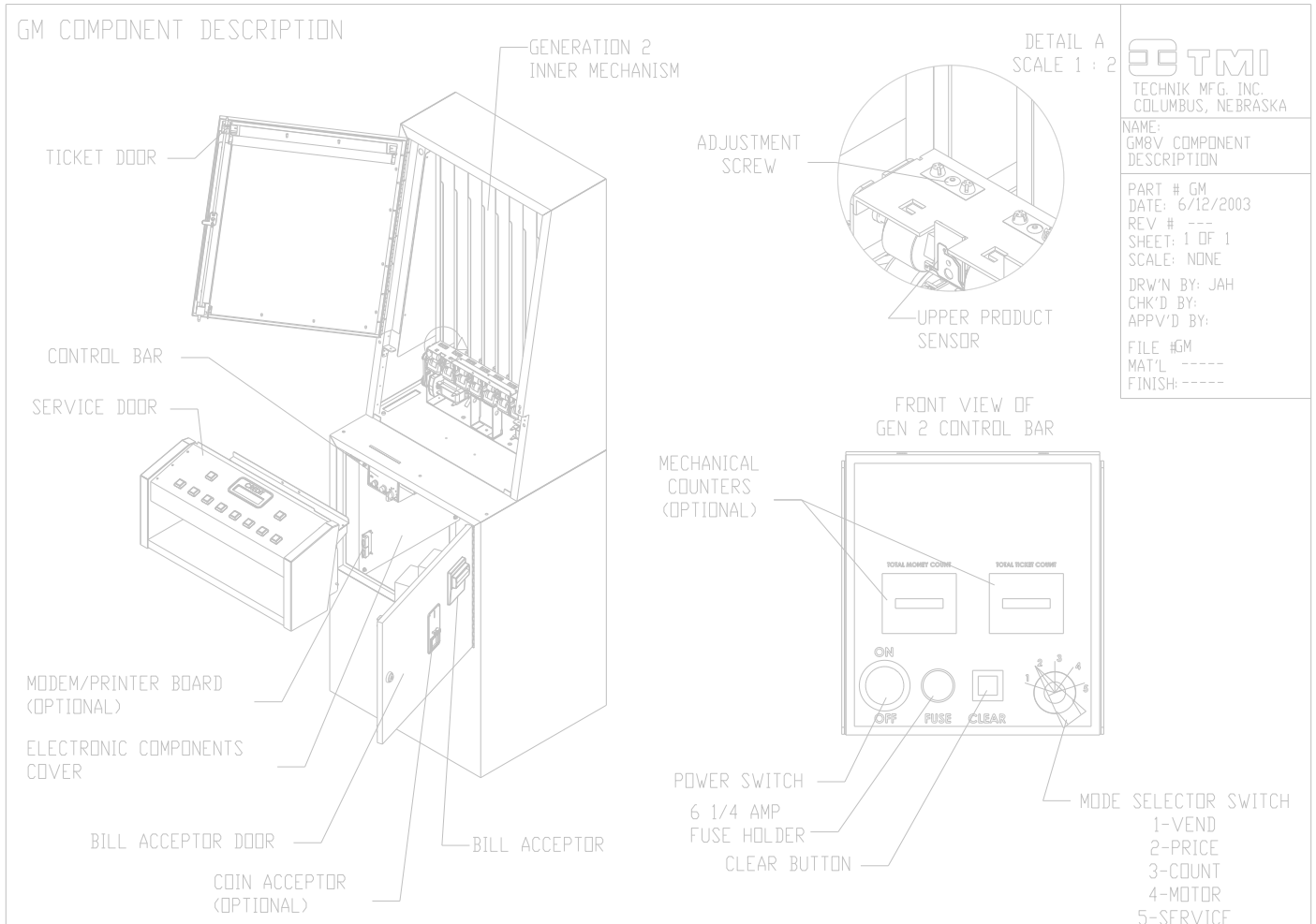

MACHINE MOUNTING

If machine mounting to a wall is required, there are four holes at the back of the base with 16" spacing. Lag screws and washers (not supplied) can be used to fasten the machine to a wall.

If mounting to the floor is desired, holes in the base are provided, however the casters must be removed

START UP

Please be sure to check that the mechanism is free of any packing materials and that nothing interferes with its operation. Please do the same with the bill acceptor.

Plug the 3-prong plug into a grounded outlet. Turn the power on with the switch that is located behind the machine. Also turn the power on with the switch provided inside the bill acceptor compartment on the control panel.

AUTOMATIC SEQUENCING

You will note that when the machine is first turned on you will hear three short audible signals, and at the same time the display on the front of the machine will show “8888” with each audible signal. The machine will then proceed to check the motors that feed the tickets and each solenoid and its corresponding pushbutton light. At the end of the sequencing, if all systems are operational, the display will read 0.00 and all eight pushbutton lights will be flashing. If the machine detects an error in the start-up process, it will display an error code. (Reference Error Codes – beginning page 18)

RANDOM / NON-RANDOM MODE

When the toggle switch located on the machine control bar is in the “**RANDOM**” mode, tickets will be randomly dispensed based on the random column settings chosen. See page 8 of the manual for set up. When the toggle switch in the “**NON-RANDOM**” mode tickets will be dispensed out of the column chosen by the player.

SERVICE MODE

The position marked **5** is used for “**SERVICE**”. This allows the service person to operate the machine without adding counts to the counters. An audible beep is heard approximately every 15 seconds when in the service position. If the selector switch is left in this position when the doors are closed, the machine will **not** record money or tickets but will dispense tickets. The control panel will not be in the normal “**attract**” mode with flashing lights. Return the selector switch to “**VEND**” position to activate the flashing lights.

RUN MOTOR

You will note on the control bar that there is a “**MOTOR**” position **4**. This position is used in certain repair procedures for clearing jammed tickets.

OPERATING MODE SUMMARY

	Mode description	Comments	Clear count	ALL	A	B	C	D
Vend	This is the normal operating mode.		Following E-14, switches to sensor diagnostic display. Following E-15 clears permanent.	Toggle "ALL" mode.	Vend Product A	Vend Product B	Vend Product C	Vend Product D
Price	Allows setting the column pricing.		When held during power on or reset, reinitializes system memory, clears all accounting information to zero and sets all column prices to default.	Cycle column selection	Cycle price	Cycle price	Cycle Price	Cycle price
Count								
Motor	Display / clear accounting information	Number displayed is number of cards dispensed for lighted column. When the ALL button is lighted, the number displayed is the total dollars accepted		Cycle column selection	Switch between resettable and non resettable counters			
Service	Motor run	The feed motor runs continuously. This is used for making column feed adjustments.						
	Service and diagnostic mode	All normal VEND mode functions are available but accounting information (cards dispensed and dollars accepted) is not updated. Note: Credits are carried over between service and vend modes so it is important to make sure that the credits are correct before returning to vend mode. The audible alarm will sound briefly every 15 seconds.	Resets credits to zero.	Toggle "ALL" mode	Test vend product "A"	Test vend product "B"	Test vend product "C"	Test vend product "D".
Cash door log	Display cash door access log.			Advance to next entry. Display Bin #	Display event start date.	Display event start time	Display event end date.	Display event end time.
Prod. Door log								
F log	Display product door log			Advance to next entry. Display Bin #	Display event start date.	Display event start time.	Display event end date.	Display event end time
Set time	Display power fail log.			Advance to next entry. Display Bin #.	Display event start date.	Display event start time.	Display event end date.	Display event end time
Set date								
	Display or Alter current time				Advance hours	Advance minutes		
	Display or alter current date				Advance month	Advance day	Display year	Advance year

Additionally, the decimal point will be on if the value displayed was altered by the time or date set function during the event.

In order to make the log easier to access and interpret, the player control buttons will be used to select the values to display as follows:

ALL - advance to next log entry. Display Bin #.

A - display event start date.

B - display event start time.

C - display event end date.

D - display event end time.

As each value is selected, the corresponding player button will be lighted to indicate which value is being displayed.

The operating mode selector will have the following 10 positions:

Vend - Normal operating mode.

Price - Allows setting the column pricing.

Count - Display / clear accounting information.

Motor - Motor run.

Service - Service and diagnostic mode.

Cash door log - Display cash door log.

Prod door log - Display product door log.

Power fail log - Display power fail log.

Set time - Display / alter current time.

Set date - Display / alter current date.

INSTALLING PUSHBUTTONS

The pushbutton assembly includes the clear pushbutton cover, the denomination legend, the white plastic inside cover, and the pushbutton itself. Place the white inside cover on the machine pushbutton. Insert the denomination legend into the clear cover. Push the clear cover onto the pushbutton and push until it snaps on, one edge at a time. To remove the clear cover, use a thin screwdriver or knife blade and pry it loose between the clear cover and the outer shell.

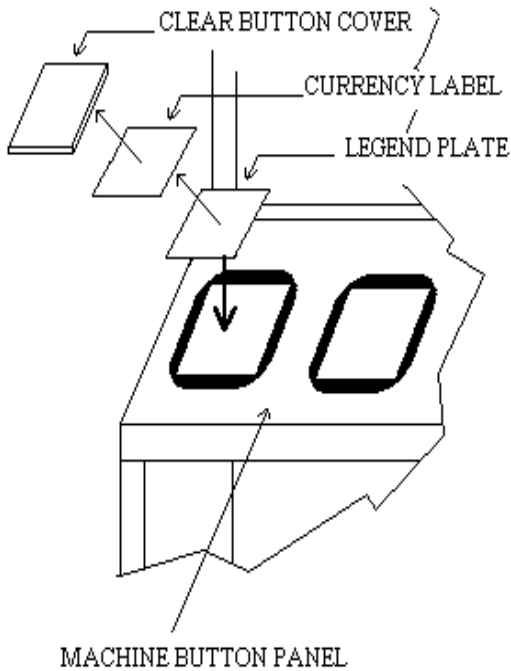

INSTALLING BUTTON COVER

REMOVING BUTTON COVER

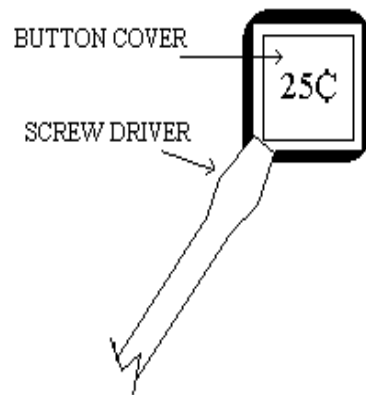

PLACE THE SCREW DRIVER AT THE EDGE OF THE BUTTON COVER AND TWIST THE DRIVER UP. REPEAT THIS FOR THE REMAINING EDGES.

IMPORTANT: BE SURE TO GO THROUGH THE “**PRICING THE MACHINE**” SECTION OF THIS MANUAL AFTER CHANGING THE CURRENCY LABELS!!!

COLUMN PRICING AND RANDOM COLUMN SETTINGS

You are now ready to set the price for each column. Minnesota rules require that tickets dispense randomly or that all tickets within the same game must dispense from at least 2 columns randomly such that the player cannot select which of the two columns.

Therefore, the machine needs to be told which columns contain Game A, Game B, etc.

The machine is designed to have the largest games in the left-most rows, and so on. You will notice that when you set the selector switch to position 2 – “**PRICING**”, that one of the digit(s) in the left column of the following table will appear:

DISPLAY READING	GAME IN COLUMN #1	GAME IN COLUMN #2	GAME IN COLUMN #3	GAME IN COLUMN #4	GAME IN COLUMN #5	GAME IN COLUMN #6	GAME IN COLUMN #7	GAME IN COLUMN #8
8	A	A	A	A	A	A	A	A
62	A	A	A	A	A	A	B	B
53	A	A	A	A	A	B	B	B
44	A	A	A	A	B	B	B	B
422	A	A	A	A	B	B	C	C
332	A	A	A	B	B	B	C	C
2222	A	A	B	B	C	C	D	D

RANDOM COLUMN / GAME SET UP CHART

WHEN 8 APPEARS ON THE SCREEN, 8 ROWS WILL BE ONE RANDOM GAME (A). IN THIS CASE, YOU WILL LOAD ONLY ONE LARGE GAME INTO THE MACHINE.

WHEN 62 APPEARS ON THE SCREEN, THE LEFT 6 ROWS WILL BE ONE LARGE RANDOM GAME (A) AND THE RIGHT 2 ROWS WILL BE RANDOM GAME (B).

WHEN 44 APPEARS ON THE SCREEN, THE LEFT 4 ROWS WILL BE RANDOM GAME (A) AND THE RIGHT 4 ROWS WILL BE RANDOM GAME (B).

AND SO ON....

You change the random row settings by pushing the red “**CLEAR**” button on the control panel. The row buttons light up corresponding to the game chart above. Once you have decided the number of games you wish to load, you are ready to set the price of each game.

Press the “**ALL**” button on the game panel to price each game. The left button lights up with a new price displayed with each push. First 199 will appear then 2.00, 1.00, .75, .50, .25, then 199 again. At the desired price for the game, press the “**ALL**” button to price the next game...and so on...

Once all of the games are priced, it is a good practice to cycle through all games by pressing the “**ALL**” button to visually make certain that all rows are priced correctly. Once you have priced all eight rows, return the rotary switch to the “**VEND**” position.

CARD THICKNESS ADJUSTMENT PROCEDURE

1. With a 9/64" hex head wrench, turn the adjustment screw on the dispenser counterclockwise until a card will not pass the adjustment mechanism.
2. Place the supplied calibration card in the bottom of the column.
3. Place card weight on top of the card with the word "FRONT" facing forward.
4. Insert the hex head wrench into the adjustment screw.
5. Try to dispense the card and turn the adjustment screw clockwise until the card is dispensed. It may take a few tries before the card is dispensed smoothly.
6. Once the card is dispensed, the column is properly adjusted.

ADJUSTMENT SCREW FOR EACH COLUMN

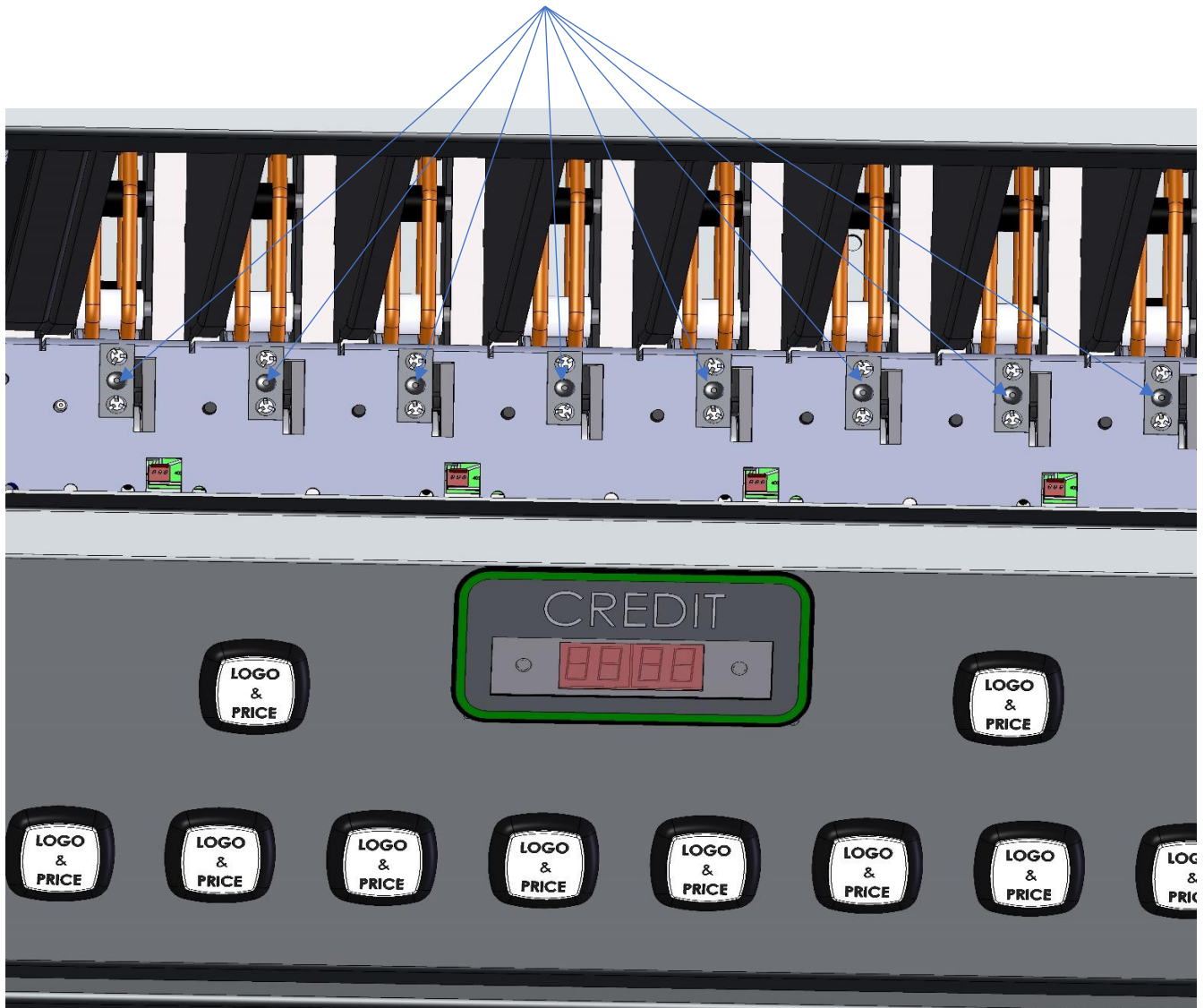

LOADING CARDS / UNLOADING CARDS

Before loading cards into the dispensing mechanism, please make sure the three-tab adaptor for each row is positioned correctly. The three-tab adaptor is located at the right and to the rear of each row. This three-tab adaptor can be positioned for dispensing either 3-window or 5-window cards.

Note the following illustrations on pg. 10 & pg. 11.

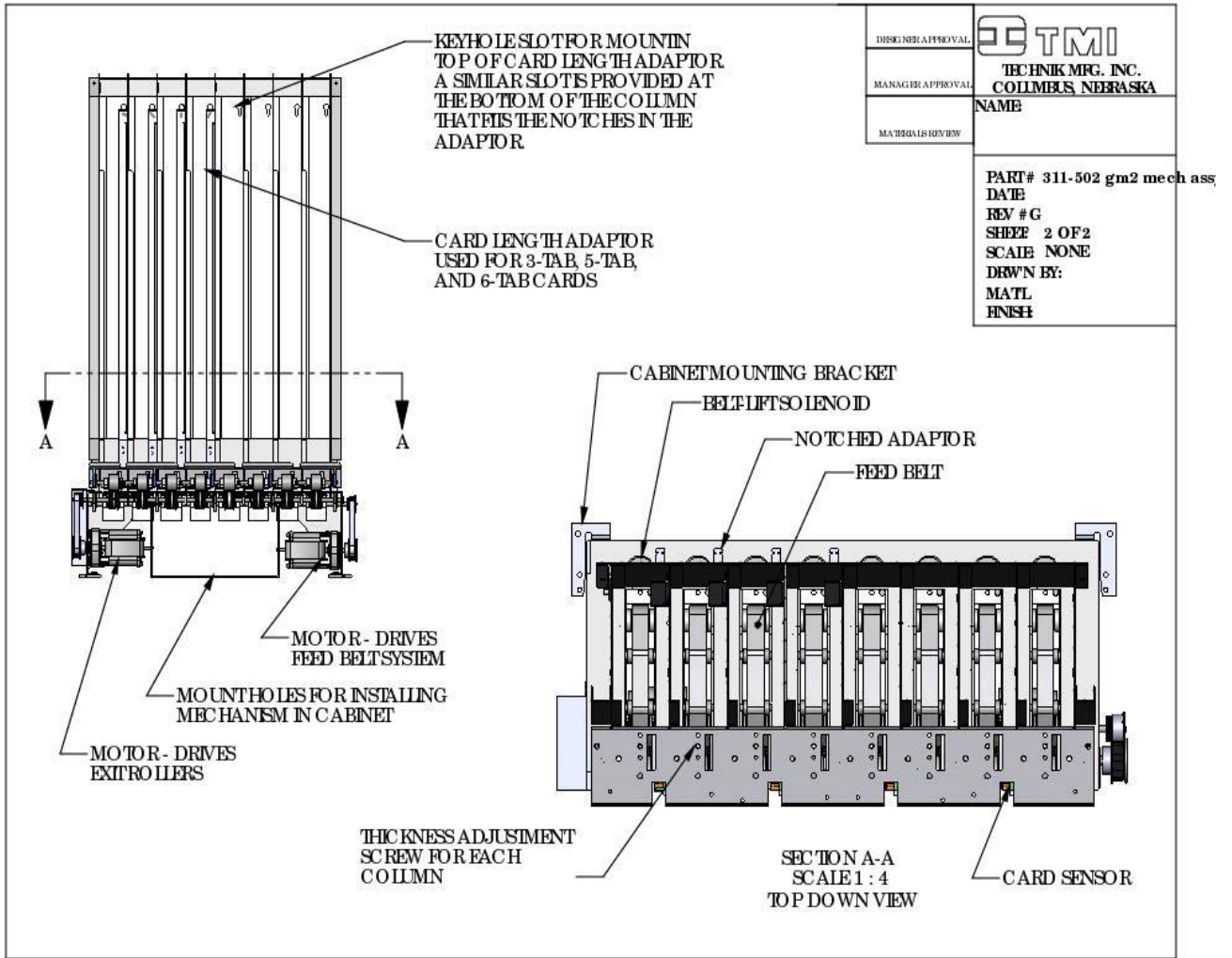

LOADING CARDS / UNLOADING CARDS (continued)

REVISION HISTORY					
REV.	DESCRIPTION	DATE	DESIGNER APPROVAL	MANAGER APPROVAL	MATERIALS REVIEW
A	MANUAL DOCUMENTATION	3/118/10			

SHORT CARDS (3-TAB) CONFIGURATION



LONG CARDS (5-TAB) CONFIGURATION





USE 3-TAB NOTCH WHEN INSTALLING IN COLUMN



USE 5-TAB NOTCH WHEN INSTALLING IN COLUMN

TECHNIK MFG. INC. COLUMBUS, NEBRASKA
NAME CARD LENGTH ADPT INSTRUCTIONS
PART # 300-031 manual asm in
DATE
REV #
SHEET 1 OF 1
SCALE NONE
DRWN BY:
MATL
FINISH

Now load the cards into the columns. If the cards are bowed, they must be stacked in the columns so that the bow is down. Place a weight on each stack of cards to ensure proper dispensing. Once the cards are loaded and the selector switch is in the **“SERVICE”** position, you may place money in the machine to check its operation. Try \$1.00, \$5.00, \$10.00, and \$20.00 bills to make sure the bill acceptor is giving proper credits; then begin to dispense cards row by row. As you begin to dispense cards, make sure they are coming out of each row in the proper denominations and the row is functioning properly.

***Use the provided card hook to remove cards from the columns*.**

CHECKING CARD AND MONEY COUNT

The Minnesota Grand Master has “**resettable**” and “**non-resettable**” accounting information. This information can be obtained with the rotary switch on the control bar. Move the rotary switch to the “**COUNT**” position. While the switch is on “**COUNT**,” all accounting information can be viewed on the display on the front of the machine.

RESETTABLE ACCOUNTING INFORMATION

While the rotary switch is in the “**COUNT**” position the “**ALL**” button will be lit. To view the ticket counts in each row press the “**ALL**” pushbutton. At this point, row “**A**” (far left pushbutton light) will be lit. The number on the display is indicating the number of tickets dispensed from that row. Press the “**ALL**” pushbutton once again. Now the next pushbutton (row “**B**”) light is lit, and the number on the display is indicating the number of tickets dispensed from that row. Continue to press the “**ALL**” pushbutton to view the accounting information for the remaining rows. Push the “**ALL**” pushbutton one more time to view the total money that the bill acceptor has received since the last time the counts were cleared. The total number of re-settable counts is 9. This includes the ticket count for each of the 8 rows, and 1 for the total dollar count when the “**ALL**” button is lit.

Each row can be cleared to zero by pushing the “**CLEAR COUNT**” button on the control bar. **NOTE:** All rows must be cleared individually as the accounting information is displayed. Pushing the “**CLEAR COUNT**” button once **DOES NOT** clear all of the accounting information.

NON-RESETTABLE ACCOUNTING INFORMATION

To access this information, move the rotary switch on the control bar to the “**COUNT**” position. The “**ALL**” button will be lit. Press the “**ALL**” pushbutton on the front button panel this will light the far-left pushbutton (row “**A**”). Press row “**A**” pushbutton again. The display will now be flashing a 3-digit number, then a 4-digit number, then the 3-digit number again. The 3-digit and 4-digit numbers are combined to make a 7-digit number. See the following example:

EXAMPLE: 000, 0150, 000, 0150 ==> 0000150

To view the non-resettable ticket counts of each row, press the “**ALL**” pushbutton. The number on the display is indicating the number of tickets dispensed from that row. Press the “**ALL**” pushbutton once again. Now the next pushbutton (row “**B**”) light is lit, and the number on the display is indicating the number of tickets dispensed from that row. Continue to press the “**ALL**” pushbutton to view the accounting information for the remaining rows. Press the “**ALL**” pushbutton one more time to view the total money that the bill acceptor has received. After viewing the non-resettable counts, press the “**ALL**” pushbutton and then the far-left pushbutton (row “**A**”) and this will return you to the resettable counts.

Return the rotary switch to “**VEND**” on the control panel and this will return the machine to normal operation.

RESETTING COUNTS

The procedure for resetting counts is to simply press the “**CLEAR**” button on the control panel as the count is displayed. This procedure has to be performed 9 times if you wish to clear all 9 counts. (All eight columns plus the ALL button)

OPENING / CLOSING RECORDS – CASH DOOR

This machine has recorded the last 25 occurrences where the cash door has been opened and closed. It records the time, date, and sequence of these events.

To operate, place the selector switch to position **6**, “**CASH DOOR**”. You will first see the number 1. This indicates that you will next see the readings for the most recent opening of the cash door.

Press the far-left row button on the game panel. This will display the date the cash door was last opened.

Press the second button from the left to display the military time the cash door was last opened.

Press the third button from the left to display the date the cash door was closed.

Press the fourth button from the left to display the time the cash door as closed.

Press the “**ALL**” button to check occurrence 2, the next most recent time the cash door was opened, etc.

OPENING / CLOSING RECORDS – PRODUCT DOOR

This machine has recorded the last 25 occurrences where the product door has been opened and closed. It records the time, date, and sequence of these events.

To operate, place the selector switch to position **7** “**PRODUCT DOOR**”. You will first see the number 1. This indicates that you will next see the readings for the most recent opening of the product door.

Press the far-left row button on the game panel. This will display the date the product door was last opened.

Press the second button from the left to display the military time the cash door was last opened.

Press the third button from the left to display the date the product door was closed. Press the fourth button from the left to display the time the product door was closed. Press the “**ALL**” button to check occurrence 2, the next most recent time the cash door was opened.

POWER OFF / ON RECORDS

This machine has recorded the last 25 occurrences the machine has lost and gained power. It records the time, date, and sequence of these events. To operate, place the selector switch to position **8**, "**POWER OUTAGE**". You will first see the number 1. This indicates that you will next see the readings for the most recent occurrence. Press the far left row button on the game panel. This will display the date the last power outage occurred. Press the second button from the left to display the military time the last power outage occurred. Press the third button from the left to display the date the power was resumed. Press the fourth button from the left to display the time that power was resumed. Press the "**ALL**" button to check occurrence 2, the next most recent time the power was interrupted, etc.

RE-INITIALIZATION PROCEDURE

Just as sometimes happens with any computer, its brains get scrambled. The unit has been designed for a soft landing should this occur, i.e., no major catastrophes. It has also been designed to allow for a "**RE-BOOT**" or "**RE-INITIALIZATION**". This procedure clears the program back to its initial startup when it was new. It does not erase non-re-settable counter information or door closing information. It does, however, erase re-settable counts and current pricing. If possible, the re-settable counts should be recorded prior to performing this procedure.

To "**RE-INITIALIZE**", turn the selector switch to the "**PRICE**" position. Press the "**CLEAR**" button and hold it down. Turn the machine power off, then on again while still holding the "**CLEAR**" button down. Release the "**CLEAR**" button once the machine has proceeded through its start up cycle.

TROUBLESHOOTING

WARNING!!!! WARNING!!!! WARNING!!!! WARNING!!!! WARNING!!!!

ALWAYS UNPLUG THE MACHINE PRIOR TO SERVICING THE MACHINE

ERROR CODES

The machine has the ability to determine its own reason for not functioning. It has several error codes that will tell you where the problem is occurring. The code will appear on the display, located on the cash door. The codes that may be encountered are as follows:

- E-02** A jumper on the board is not installed properly or the counters are not connected. Contact a service technician for assistance.
- E-04** This means that a card was in the process of being dispensed when the machine lost power. The **E-04** appeared on the screen when power was restored. The machine will not function until the “**CLEAR**” button is pressed. When the **E-04** is cleared a ticket may be dispensed. This ticket has not been recorded by the machine and should be returned to the stack. This feature is intended to prevent tampering/theft of cards. If this error code appears frequently, it is likely that someone is trying to manipulate free tickets.
- E-10** This means that the machine has lost its memory, the row denominations will default to the default pricing and the counts will be cleared. This indicates the machine needs to be re-initialized – see the “**Initializing Procedure**” section of this manual.
- E-11** This means that the signal received from the bill acceptor took too little time. This is a security feature. If someone had somehow found a way to send electrical signals to the circuit board to add credits to the machine, they would not know of this feature and the machine would produce either an **E-11** or an **E-12** error code.
- E-12** This means that the signal received from the bill acceptor took too long. This is similar to **E-11** above.
- E-13** This means the selected ticket took too long to dispense. Remove the ticket from that row. To clear, turn the machine off, and then back on.
- E-14** This means that an unexpected ticket was sensed in a row other than the selected row. The unit will **ONLY** operate in the “**MOTOR**” mode. To clear this error code, turn the selector switch to the “**MOTOR**” position. This will cause the motor to run for 1.5 seconds to clear the sensed ticket. Once the sensed ticket is cleared, turn the rotary switch to the “**VEND**” position and turn the power off, then

on again. Repeat this procedure if the error code was not cleared on the first attempt.

** The control board is programmed with a sensor diagnostic and can be viewed if the **E-14** error codes are frequent. To enter this diagnostic, follow the procedure below:

- 1) With **E-14** present on the display and the selector switch in the “**VEND**” position, push the “**COUNT CLEAR**” button on the control board.
- 2) The display will now be showing the status of the sensor for each row. To understand this information please refer to the diagram(s) below.

For the diagnostic, the display uses eight vertical bars, each bar representing the corresponding product column. Either the upper or lower half of each bar is lighted to indicate the status of the column sensor. The upper half is lighted when the sensor is unblocked. The lower half is lighted if the sensor is blocked or not installed.

- 3) If a row does have a faulty sensor, please contact a service technician for assistance.
- 4) To exit the sensor diagnostic, turn the machine off, and then back on.

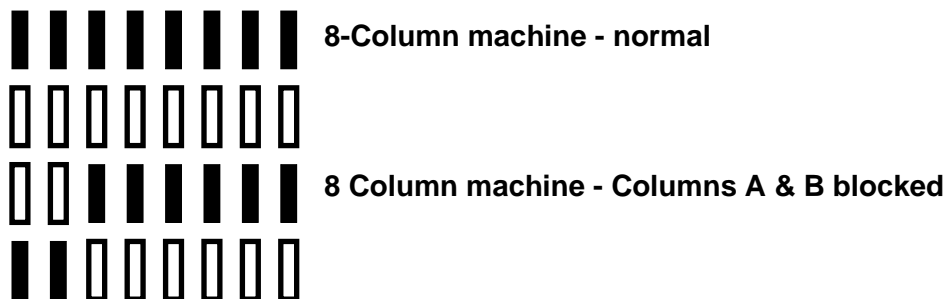

E-15 This means that the non re-settable counters have been corrupted due to loss of memory. It is possible to view the corrupted counters by using the procedure under **E-10**. While **E-15** is displayed, pressing “**COUNT CLEAR**” will clear the error code and the machine will reset itself. **NOTE:** The counts on the non re-settable counters will be zero after clearing procedure. In Minnesota, regulations require that this situation be reported. Please contact Technik Mfg., Inc. for details.

E-20 This means that it took too long to dispense a ticket. See the procedure for clearing a jam. The machine allows the player to continue play for the balance of the credits on the machine. You will note that one button lights, thereby indicating the row that did not function properly. Often the **E-20** error code can be corrected by simply turning the machine off, then on again.

The game from which the **E-20** malfunction occurred can be re-priced to \$199 thereby not allowing play on that specific game, but allowing play of the remaining game(s).

ERROR CODES FLOW CHART

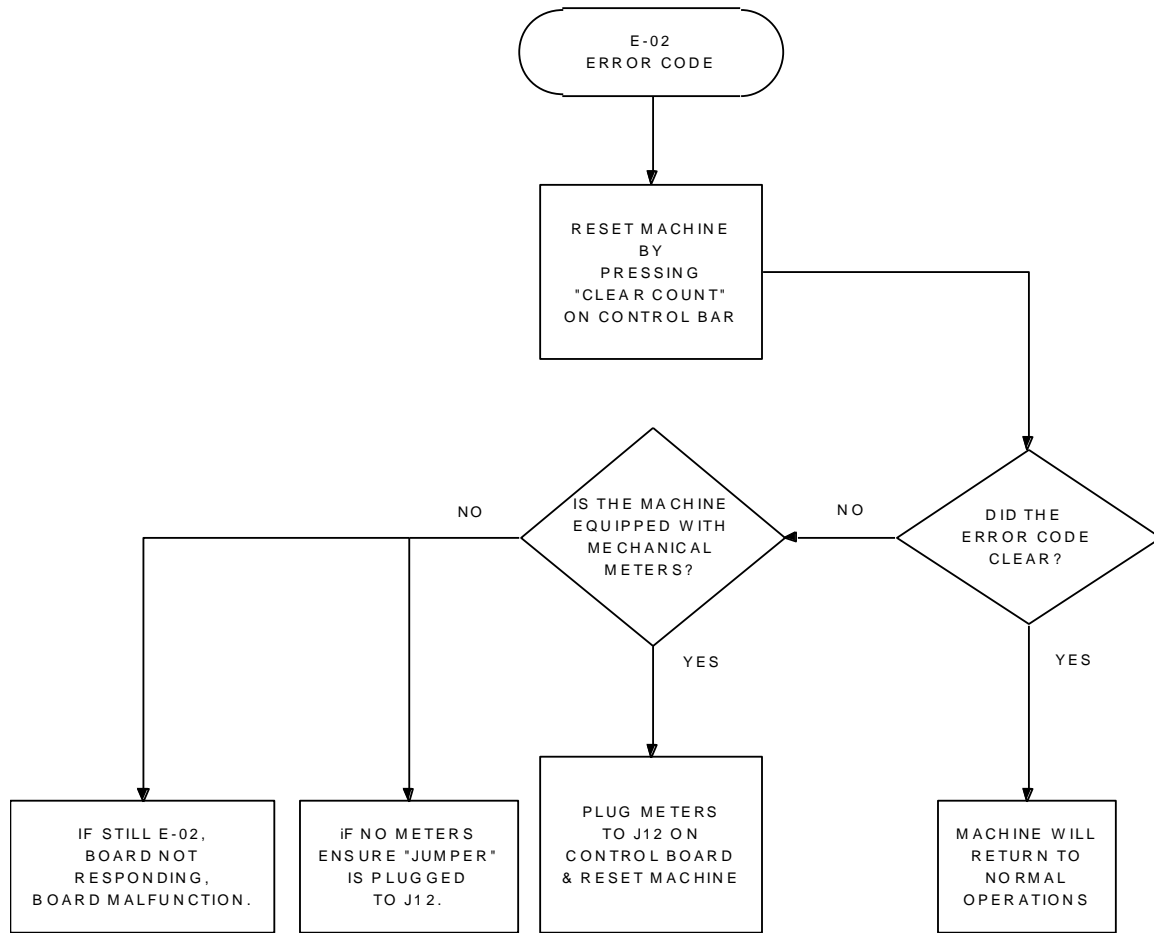

ERROR CODE FLOW CHART

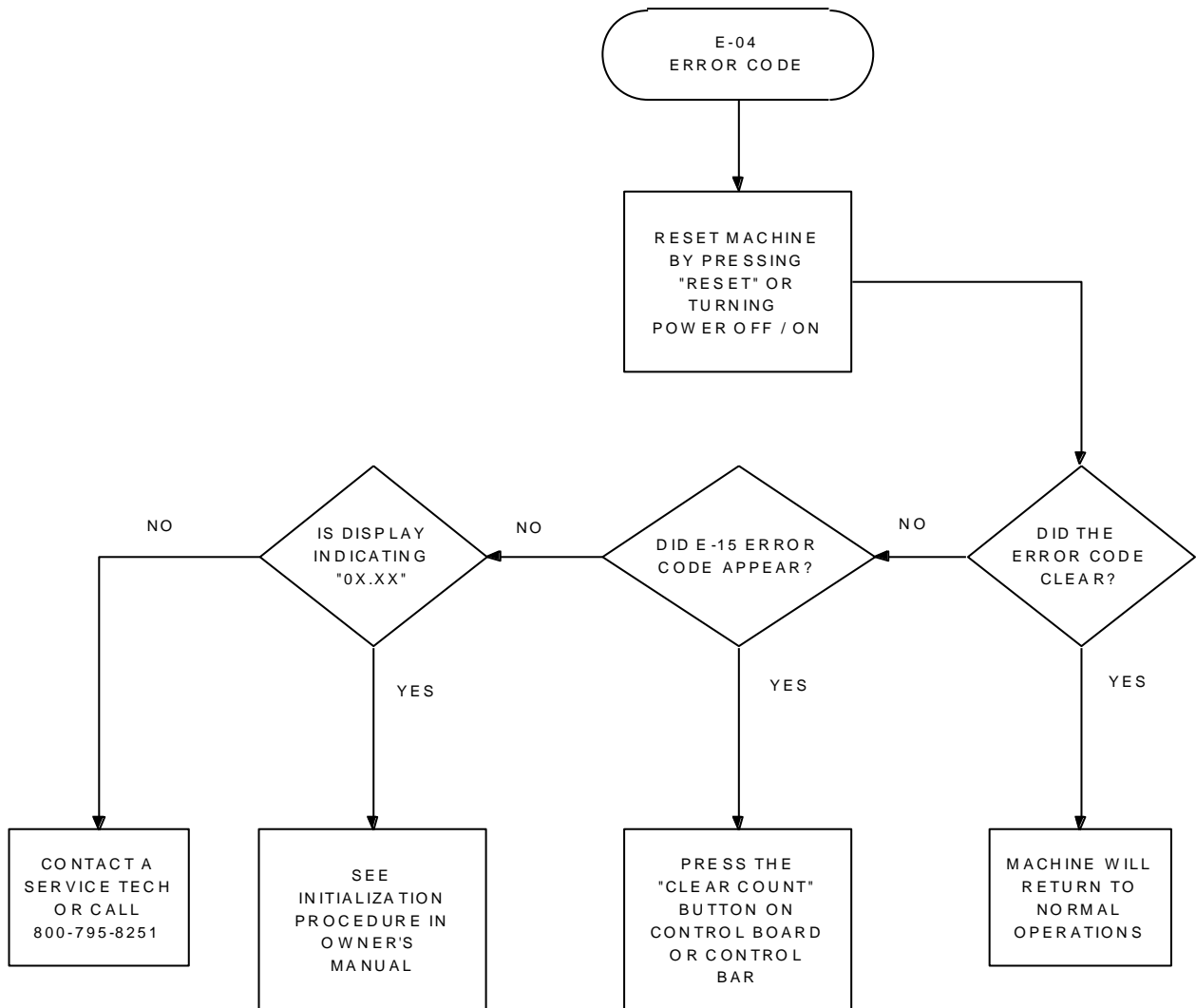

ERROR CODE FLOW CHART

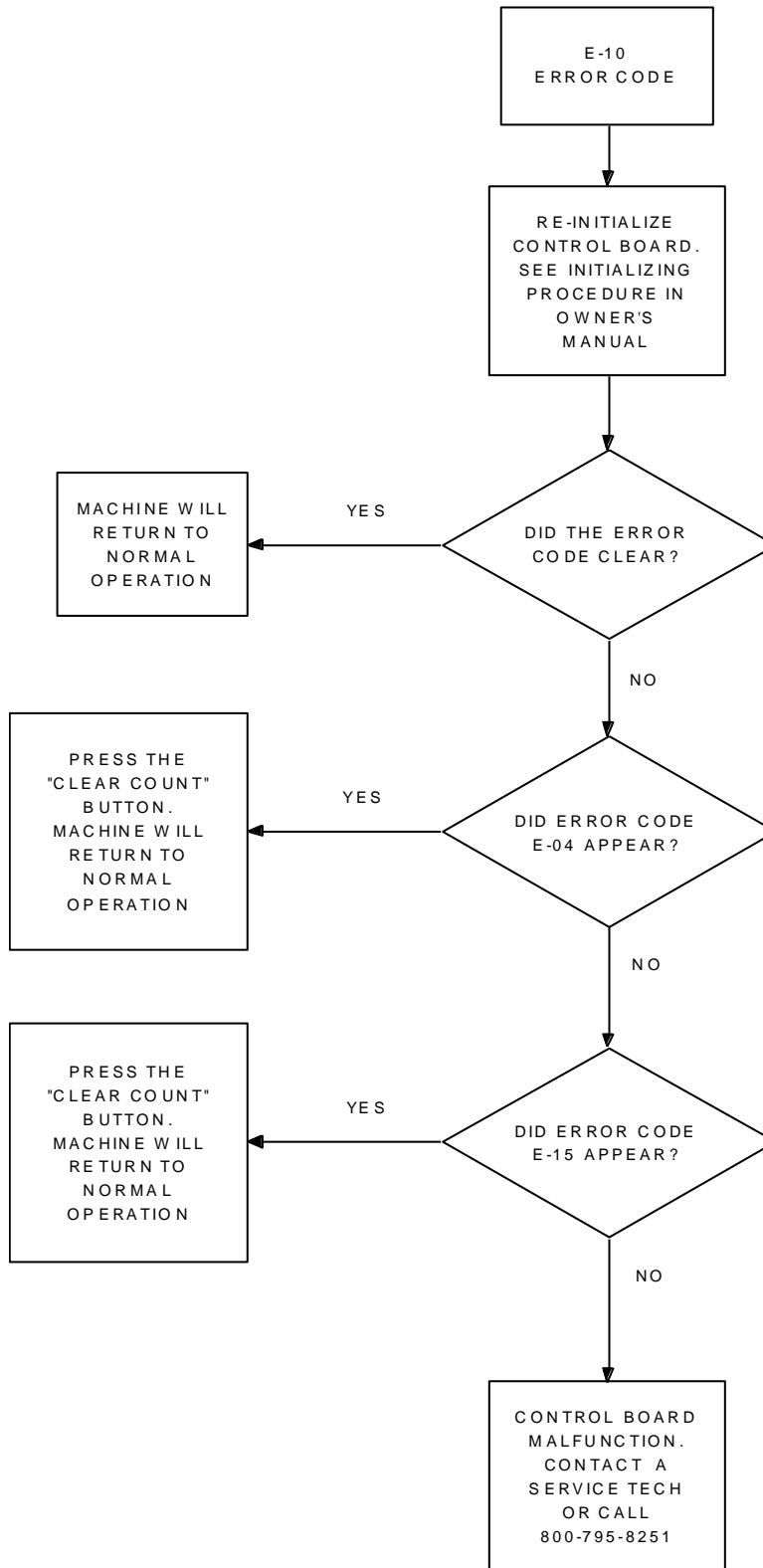

ERROR CODE FLOW CHART

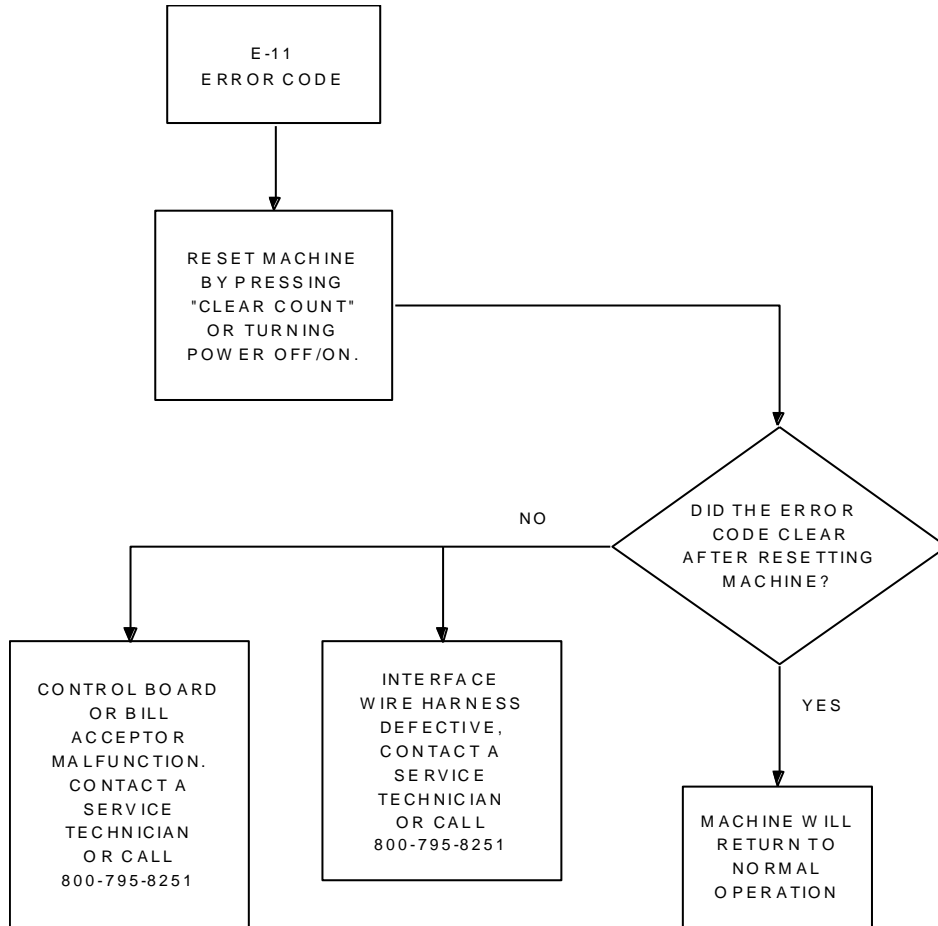

ERROR CODES FLOW CHART

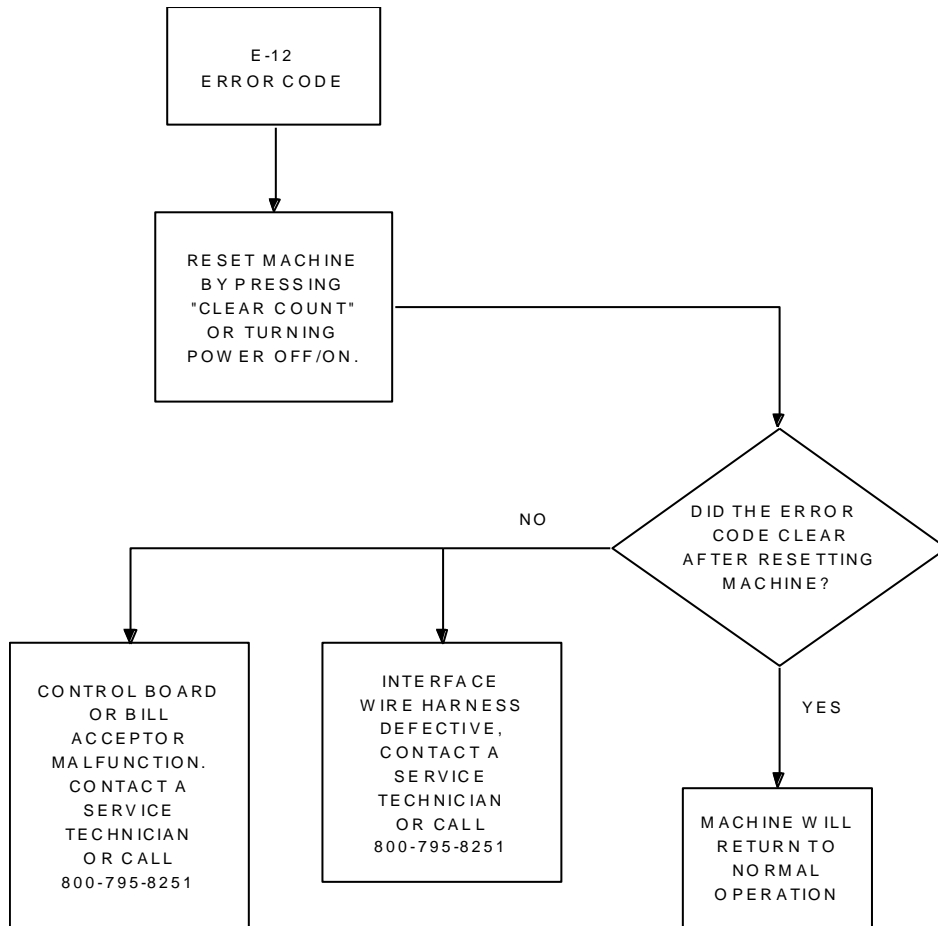

ERROR CODES FLOW CHART

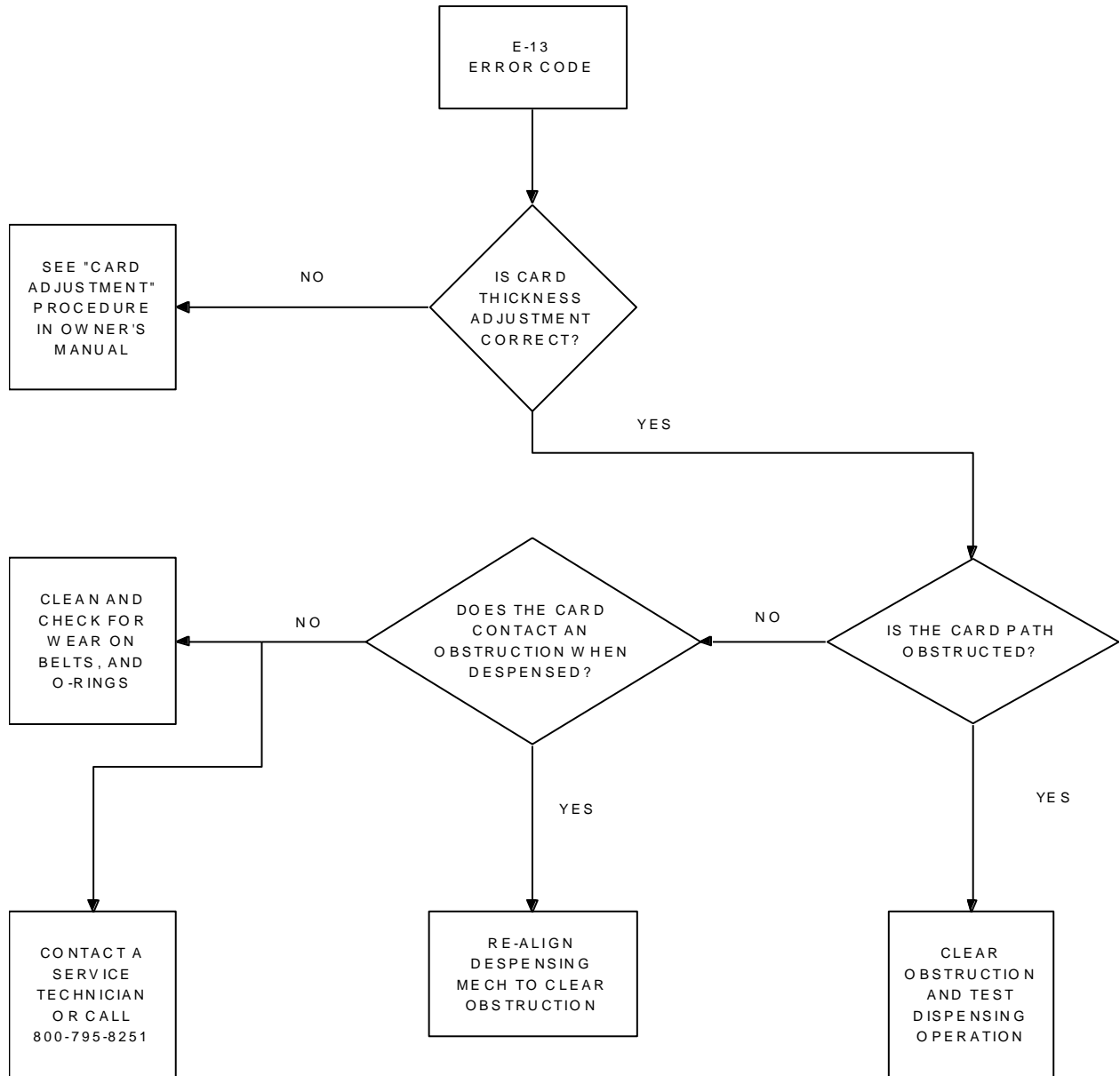

ERROR CODES FLOW CHART

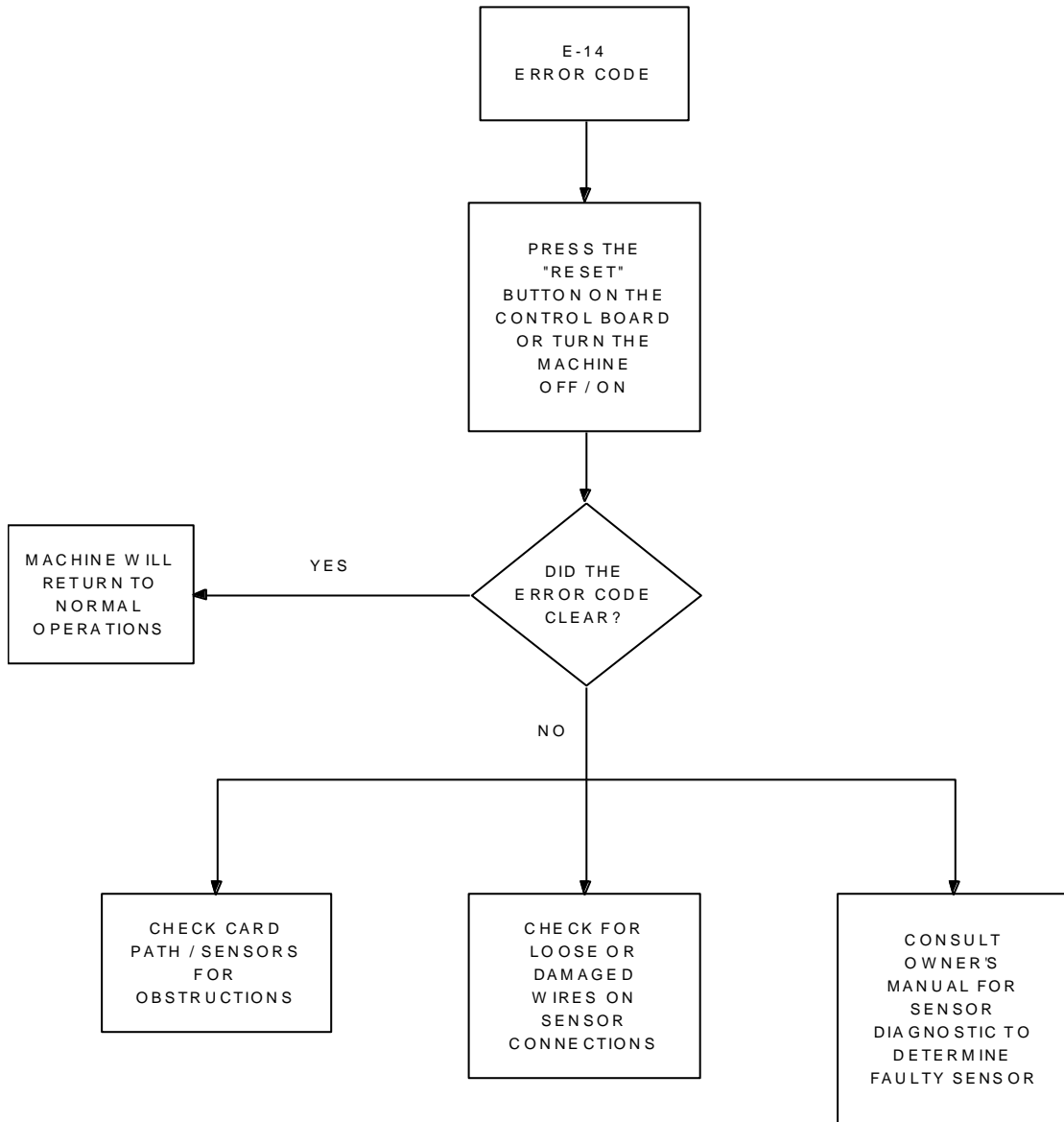

ERROR CODES FLOW CHART

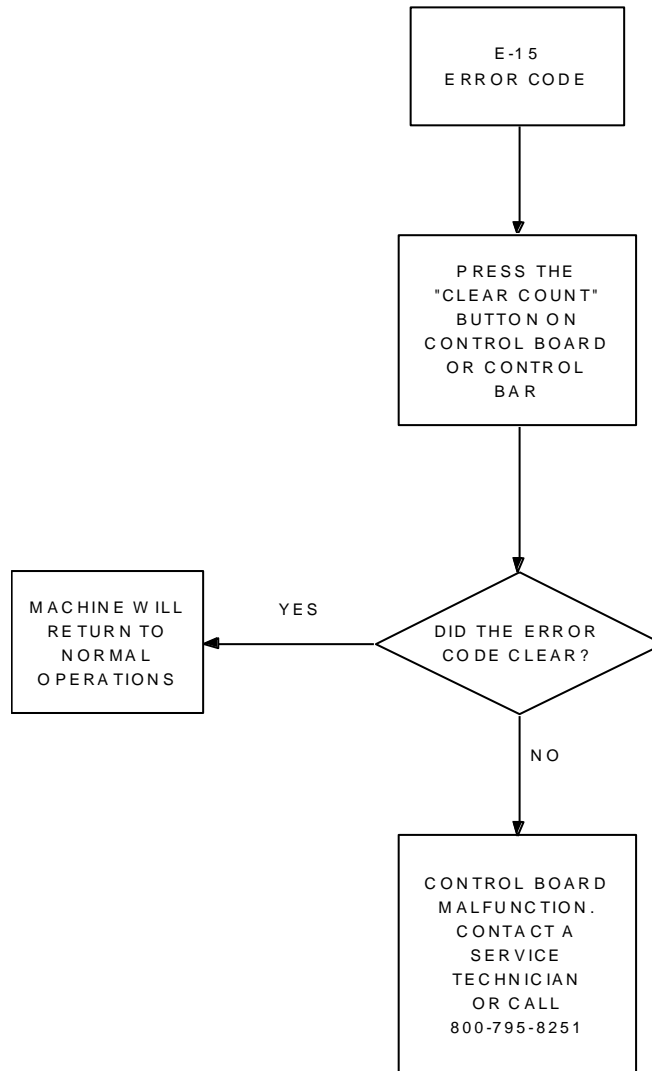

CARDS JAM OR HESITATE

- 1) Cards may be too thick or thin. Or the card gap may need to be adjusted. See **“Card Thickness Adjustment”**
- 2) Cards may be excessively warped or bowed. Call your supplier.
- 3) Cards may be glued together. The machine is designed not to accept 2 cards at once. Again, call your supplier. Also, fanning the cards prior to loading may solve this problem.
- 4) Cards may be damaged. Remove damaged cards and try again.
- 5) A loose roller may cause this problem. A loose setscrew that is intended to lock the rollers to the shaft can cause this.

CARDS JAMMING OR HESITATING FLOW CHART

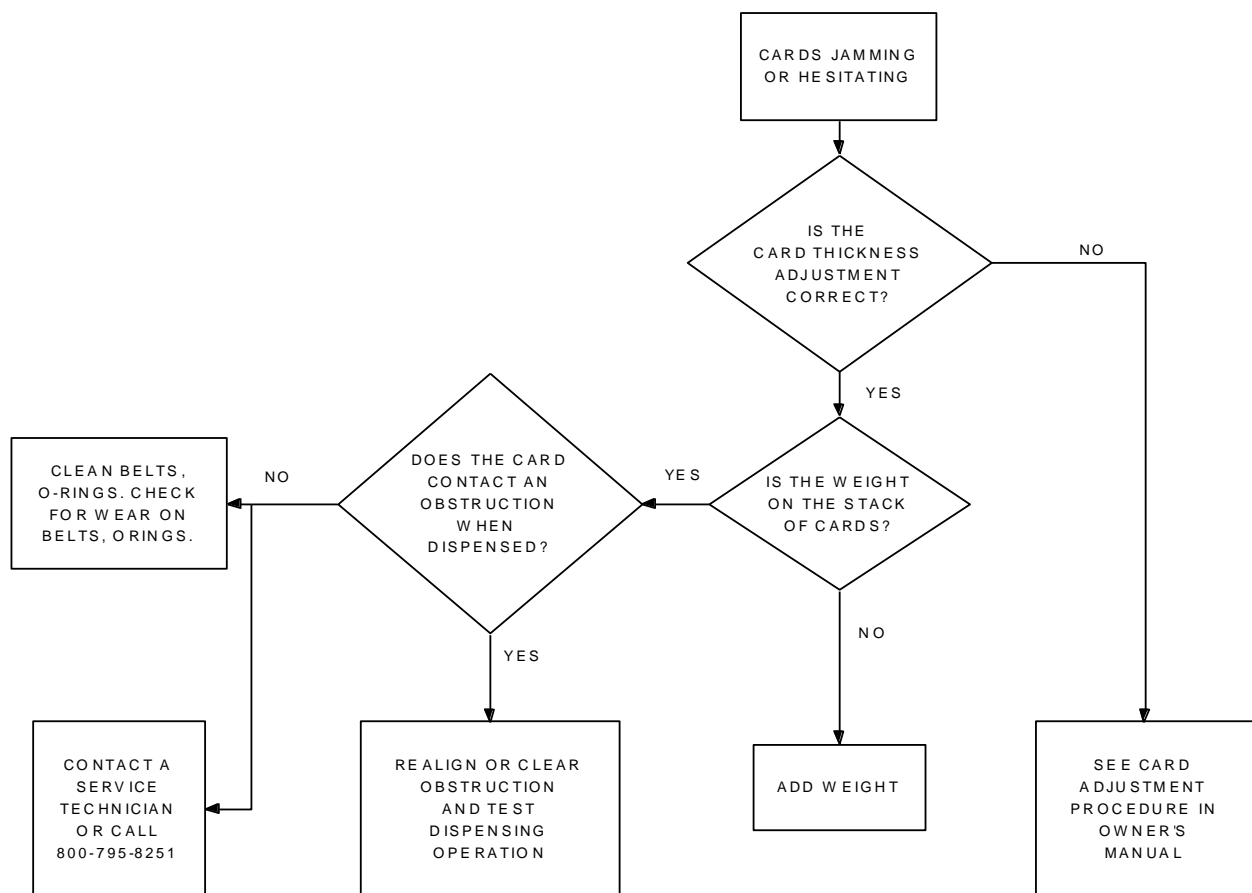

ODD COUNTS AND DISPENSING

- 1) Static electricity is a major contributor to this and all other electronic equipment. You **MUST** use a 3-prong grounded receptacle.
- 2) At times (mostly in the winter), strange static problems can occur. It may be necessary to spray the carpet area around the machine with a diluted mixture (10:1) of Downy fabric softener and water once every two weeks. **DO NOT SPRAY MACHINE.**
- 3) Total re-programming may be needed. See the “**INITIALIZING PROCEDURE**”. This procedure erases all settings and re-settable counts. The machine must now be re-programmed.
- 4) Low voltage causes many electronic problems. If your unit is plugged into an extension cord, or is on the same line with refrigeration equipment, etc., the 115-volt supply may be less than 100 volts. Have an electrician check the voltage supplied to the machine and repair as needed.
- 5) The sensor may be dirty. One sensor is built into each track just beyond the drive rollers. Should the lower sensor get filled with card shavings, it may not be able to sense. Simply blow air or use a cotton swab to clean this area.

CARDS NOT DISPENSING

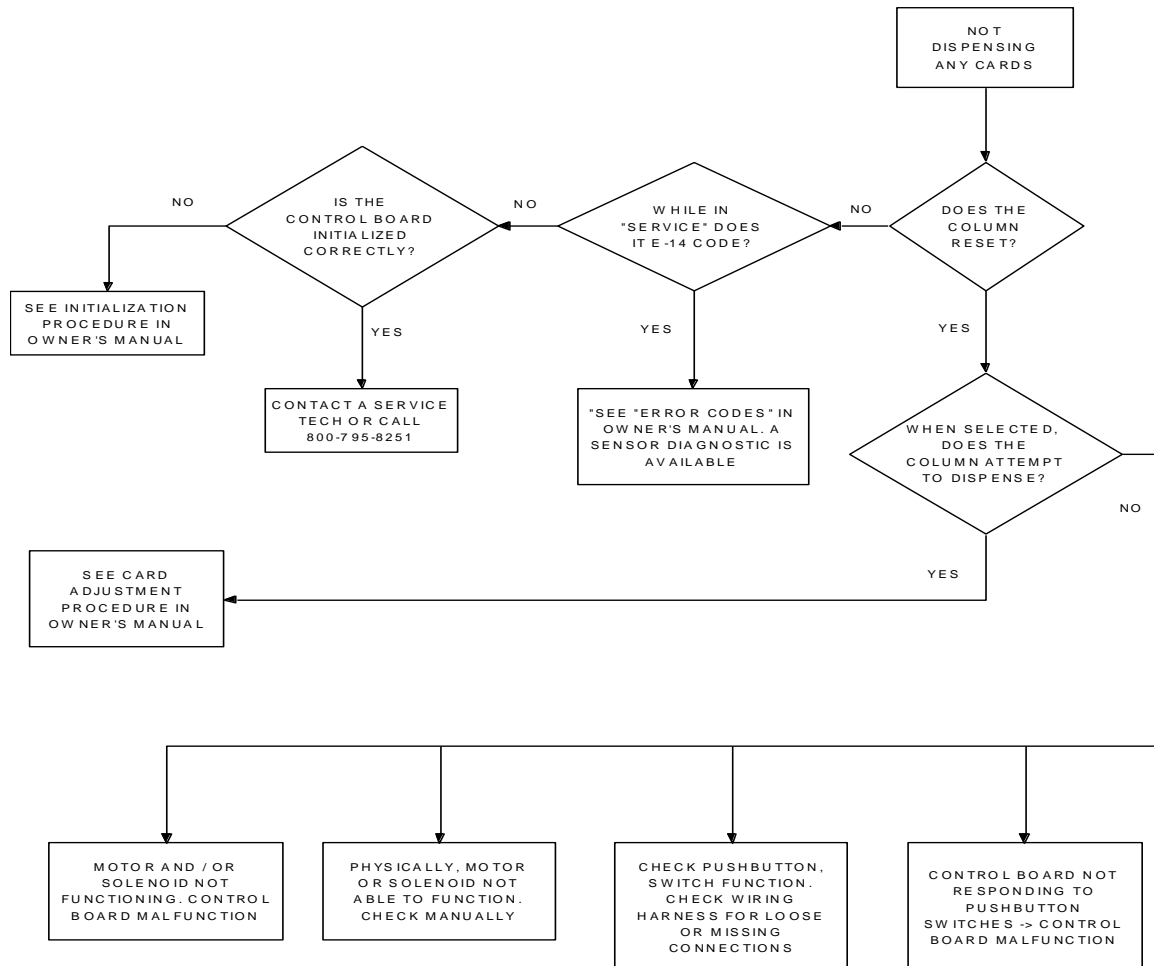

FUSE BLOWN

If the machine shuts down and nothing works, check the fuse. The machine uses a 6 ¼ AMP fuse.

NO POWER

Please be aware of the **POWER ON** switch on the backside of the steel cabinet. This switch is available for resetting certain functions on the machine without the need of opening the door and using the control panel switch.

POWER INTERRUPTIONS

It is possible that if power dies exactly at the moment a card is being delivered, the card will stop and not be delivered until power is returned and the motor is ran. The machine recognizes this situation by displaying an **E-04** error code. The machine will not operate until reset. This single ticket that was dispensed will not have been counted, nor will it have been deducted from the credit. Two possibilities then exist:

- 1)** The customer removes and plays the ticket after power has been restored. This is not a problem since the ticket has been paid for. The person at the location realizes this is due to the **E-04** error code and dispenses one additional ticket from that column and returns it to the stack. This procedure corrects the ticket count and the dollar count.
- 2)** The person at the location can simply return the ticket to the stack after it has been dispensed and allow the customer to play. This procedure also corrects the card and money count.

NO POWER FLOW CHART

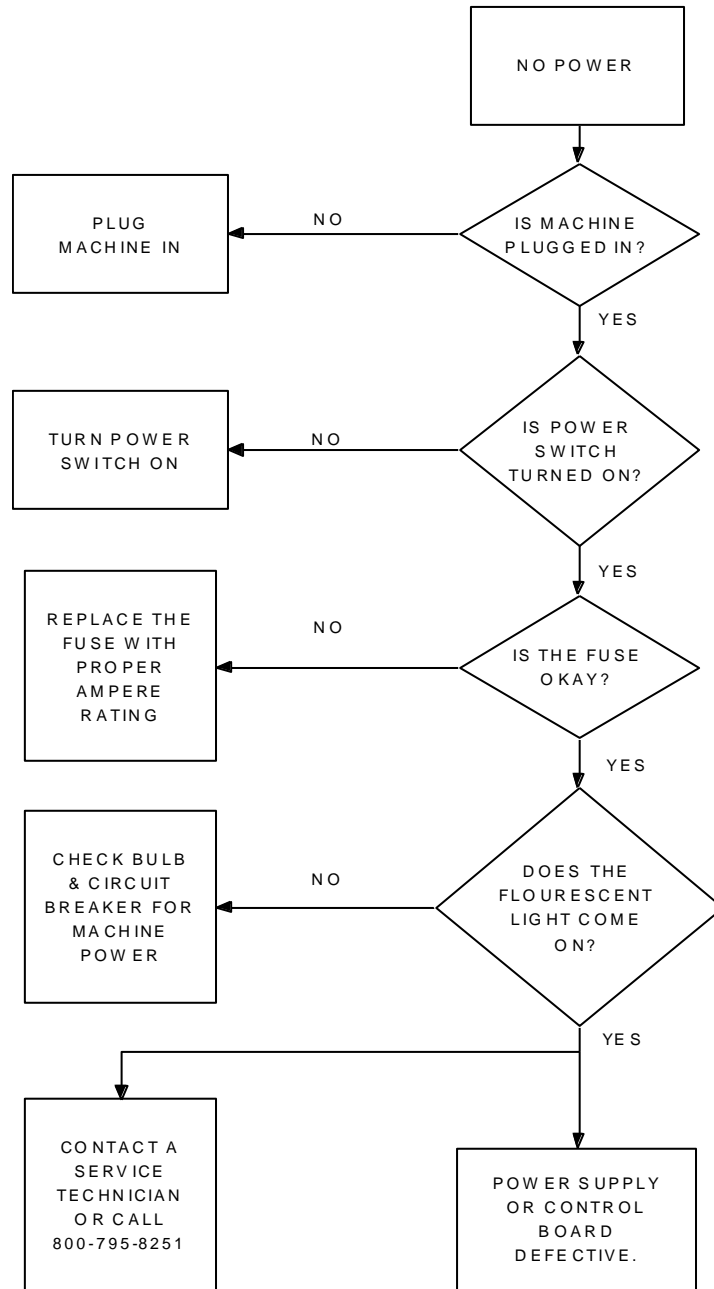

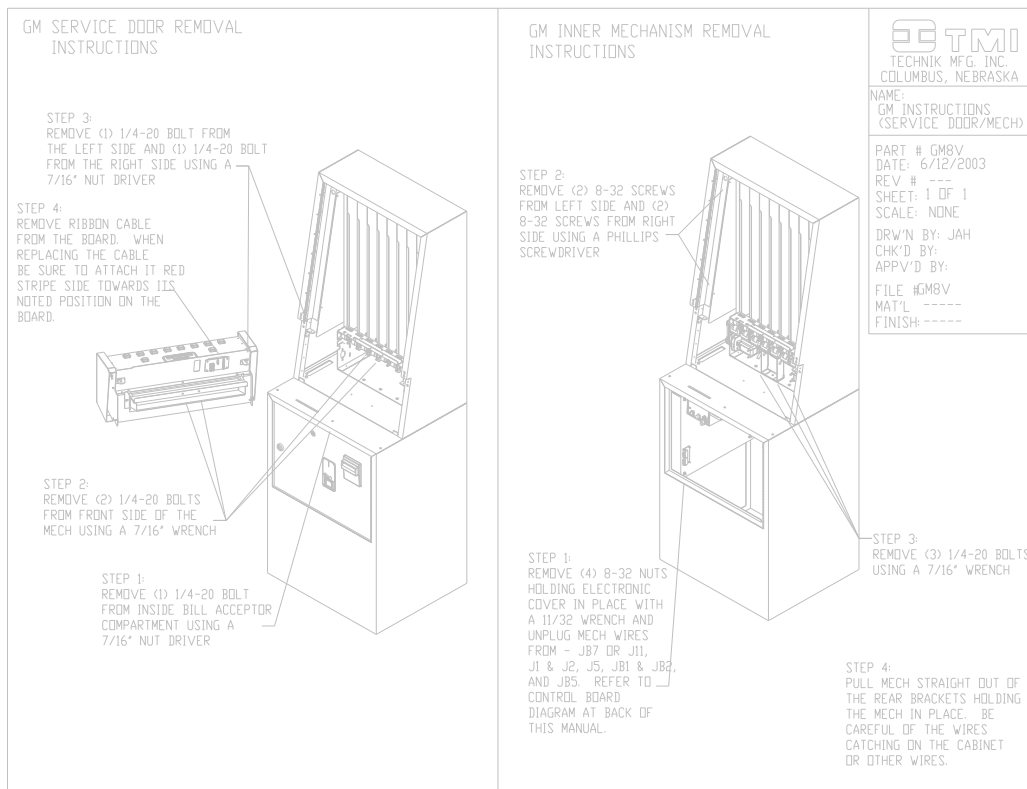

CALLING A SERVICE TECHNICIAN

Service is available at your fingertips. Simply call the number shown on the front of this book or on the label placed inside the machine.

When calling for service, PLEASE HAVE MACHINE SERIAL NUMBER READY.

SERIAL NUMBER LOCATIONS

The serial numbers are located on the inside of the main ticket door below the window, in the bill acceptor compartment on the right wall and on the front of this manual.

REGULAR MAINTENANCE

This machine requires very little regular maintenance. The bearings and the wear elements are designed for long life. However, it is recommended that the following be performed on a regular basis:

- * Blow air in the front of the mechanism onto the sensors to eliminate paper dust from covering the sensor.
- * Clean the exterior of the machine with a moist soft cloth and a window cleaning solution. The front glass is made of polycarbonate, which is bullet proof, but it is prone to scratching when rubbed with a dry cloth or rag.

5-2. DIP Switch Setting

There are two serial DIP switches which are set on the side of A6/V6 series (as FIG.01). According to different currencies which are used by users, DIP switch settings could be varied to fit users' needs. There is also a serial DIP switch on the base of the unit for inside interface settings (as FIG.02). Please refer to "A6/V6 series DIP Switch Setting Guide" in the package for more details.

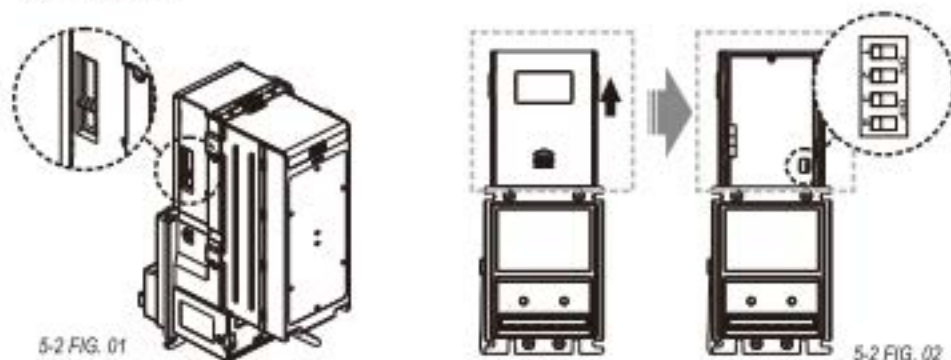

5-3. Software Download and Upgrade

To download and upgrade the software to A6/V6 Series, the programmer (FP-004) is needed. Please contact ICT to purchase FP-004 and refer to FP-004 user guide for software download and upgrade information.

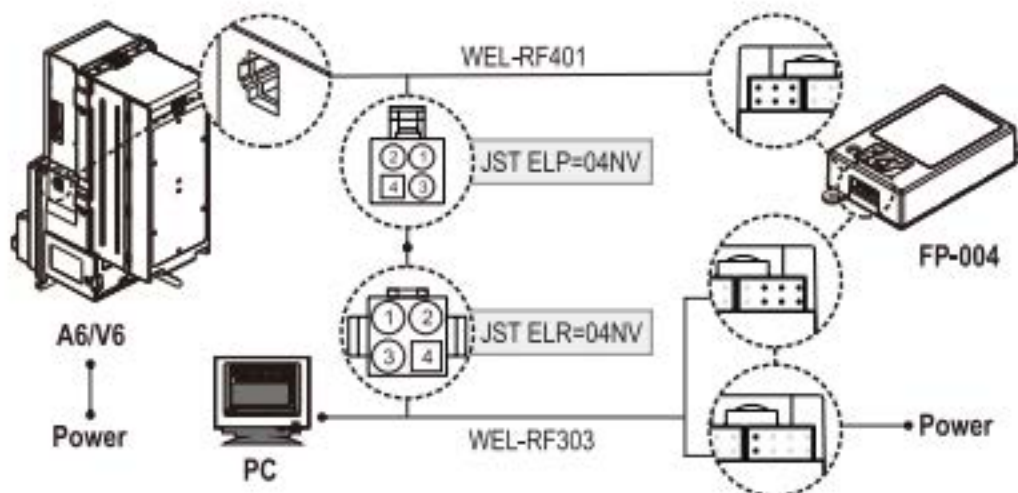

Power must be applied to Bill Acceptor **after** connecting.

6. Maintenance

To make sure the bill acceptor always works smoothly, please clean the internal parts every two weeks to every two months.

To clean the internal parts:

1. Press the buttons on the sides of bill path unit and pull the unit out.

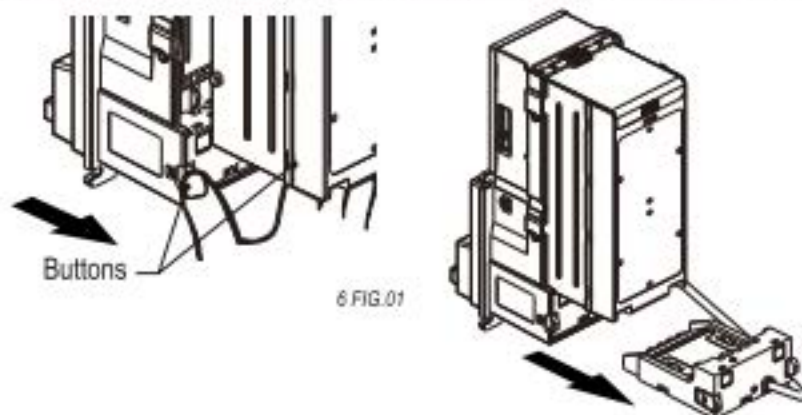

2. Use a soft, dry cloth or towel to clean the bill path and sensors.

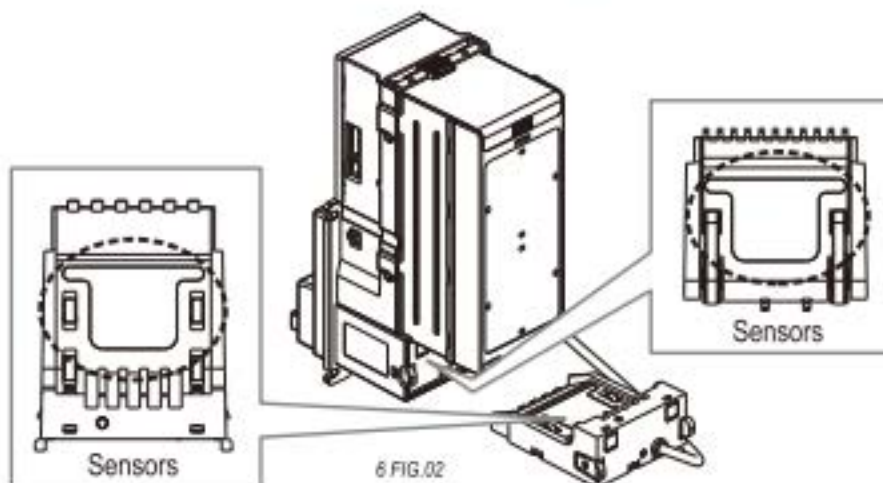

	Maintenance Notice	
	<i>(Any improper maintenance will invalidate the warranty.)</i>	
	Recommended	Mild, non-abrasive, soap water.
	DO NOT USE	Organic solvent , Alcohol, Volatile liquid.

7. Troubleshooting

7 TABLE 01

LED	Status	Corrective Actions
Green	White Card Calibration.	Please calibrate with ICT white calibration card.

7 TABLE 02

LED Flashes (Green)	Status	Corrective Actions
1	Bill jammed.	Remove the bill box by sliding the top button and the bill path unit (as 7 FIG.01), and then remove the jammed bill.
2	Disable	Inspect for right DIP switch setting.
3	Recognition sensor error.	Inspect for foreign objects on sensor or bill path and clean.
3+2	Hook sensor error.	Inspect for foreign objects on security hook and clean.
5	Bill box has been removed.	Replace the bill box.
6	Stacker error or stacker full.	Empty the bill box.
7	Motor error.	Inspect for foreign objects on bill path and clean.

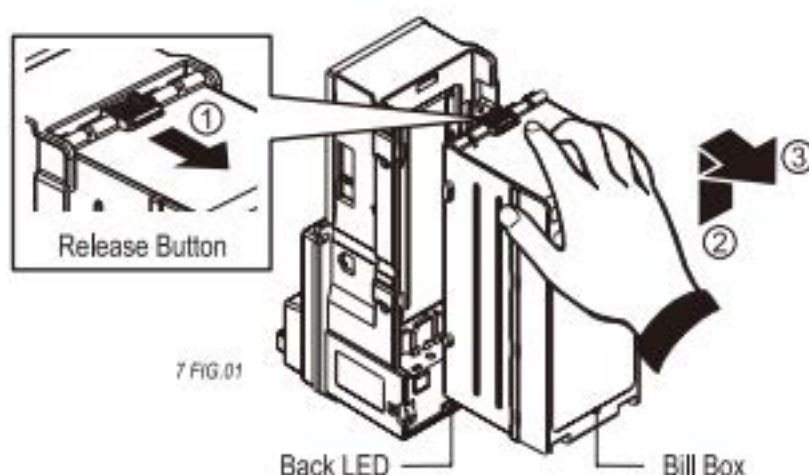

If the error can not be solved after corrective actions or happen again, please contact ICT for technical support.

5-2. DIP Switch Setting

There are two serial DIP switches which are located on the side of PA7/PA7-U(as 5-2 FIG.01). According to different currencies which are used by users, DIP switch settings could be varied to fit users' needs. Besides, there's also a serial DIP switches on CPU board inside of PA7/PA7-U for interface settings(as 5-2 FIG.02).

Please refer to "PA7/PA7-U DIP Switch Setting Guide" in the package for more details.

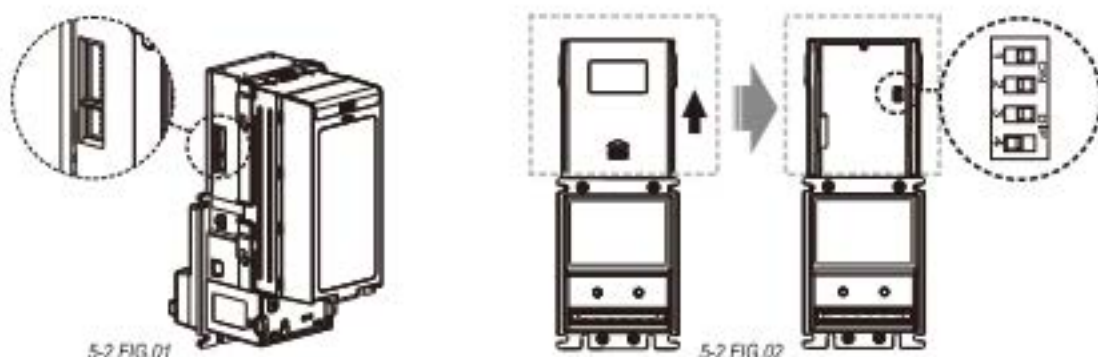

5-3. Software Download and Upgrade

To download and upgrade the software to PA7/PA7-U, the programmer(FP-004) is needed. Please contact ICT to purchase FP-004 and refer to FP-004 user guide for software download and upgrade information.

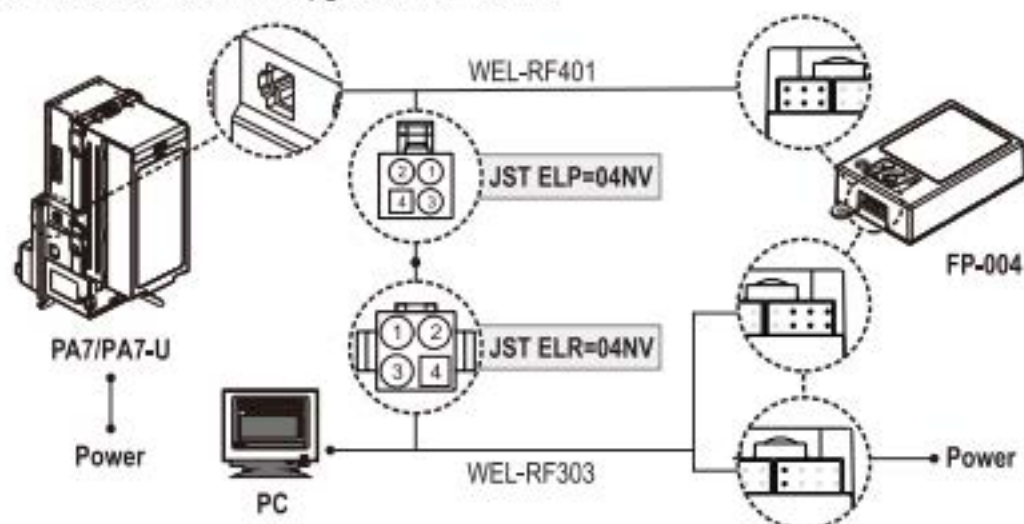

Power must be applied to Bill Acceptor **after** connecting.

6. Maintenance

To make sure the bill acceptor always works smoothly, please clean the internal parts regularly.

To clean the internal parts:

1. Press the buttons on the sides of bill path and pull the unit out.

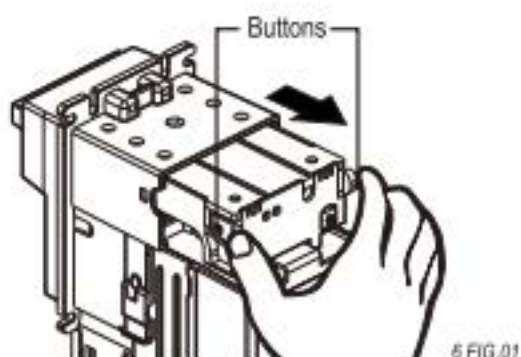

2. Use a soft, dry cloth, or towel to clean the bill path and LED/sensors.

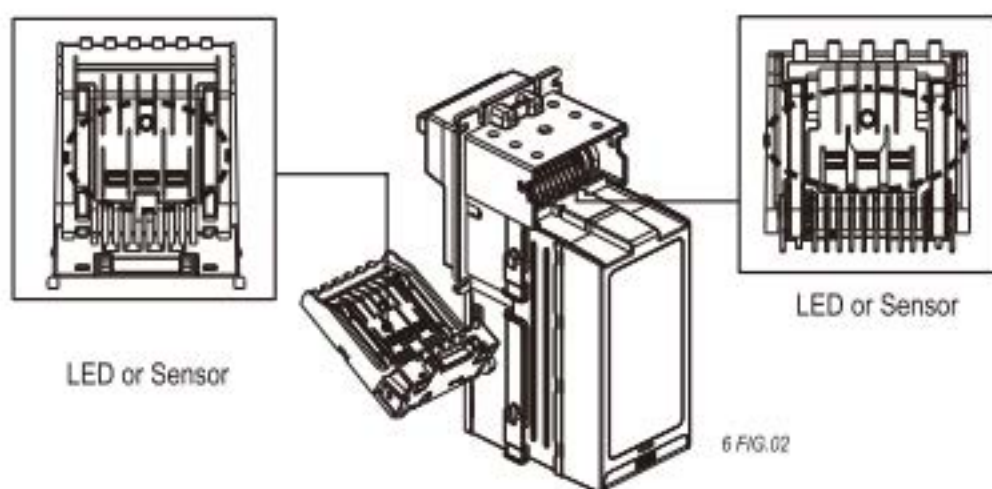

Maintenance Notice

(Any improper maintenance will result invalid warranty.)

Recommended

Mild, non-abrasive, soap water.

DO NOT USE

Organic solvent , Alcohol, Volatile liquid.

7. Troubleshooting

7-1. Bezel LED Errors



7-1 TABLE 01

LED	Status	Correct Actions
GREEN	White Card Calibration.	Please calibrate with ICT white calibration card.

7-1 TABLE 02

LED Flashes	Status	Corrective Actions
RED		
1	Bill jammed.	Remove the bill box by sliding the top button (as 7-2 FIG.01) and the bill path unit, and then remove the jammed bill.
2	Inhibit on.	Inspect for right DIP switch settings.
3	Sensor error.	Inspect for foreign objects on sensor and hook then clean.
4	Stringing attempt has detected.	Inspect for foreign objects on sensor or bill path and clean.
5	Stacker has been removed.	Replace the bill box.
7	Motor error.	Inspect for foreign objects on bill path and clean.
8	Stacker error or Stacker full.	Inspect for foreign objects in bill box and clean or remove bills in bill box.



If the error can not be solved after corrective actions or happen again, please contact ICT for technical support.

7-2. Back LED Errors

7-2 TABLE 01

LED	Status	Correct Actions
GREEN	White Card Calibration.	Please calibrate with ICT white calibration card.

7-2 TABLE 02

LED Flashes	Status	Corrective Actions
RED		
1	Bill jammed.	Remove the bill box by sliding the top button (as 7-2 FIG.01) and the bill path unit, and then remove the jammed bill.
2	Inhibit on.	Inspect for right DIP switch settings.
3	Sensor error.	Inspect for foreign objects on sensor and hook then clean.
4	Stringing attempt has detected.	Inspect for foreign objects on sensor or bill path and clean.
5	Stacker has been removed.	Replace the bill box.
7	Motor error.	Inspect for foreign objects on bill path and clean.
8	Stacker error or Stacker full.	Inspect for foreign objects in bill box and clean or remove bills in bill box.

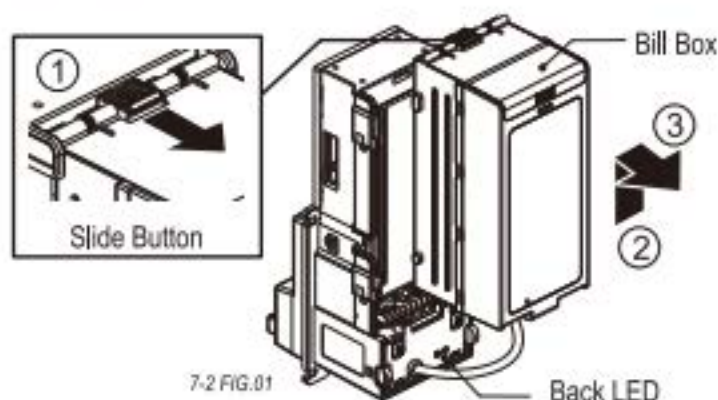

If the error can not be solved after corrective actions or happen again, please contact ICT for technical support.

TECHNIK MFG, INC. CONTROL BOARD P/N 110-090

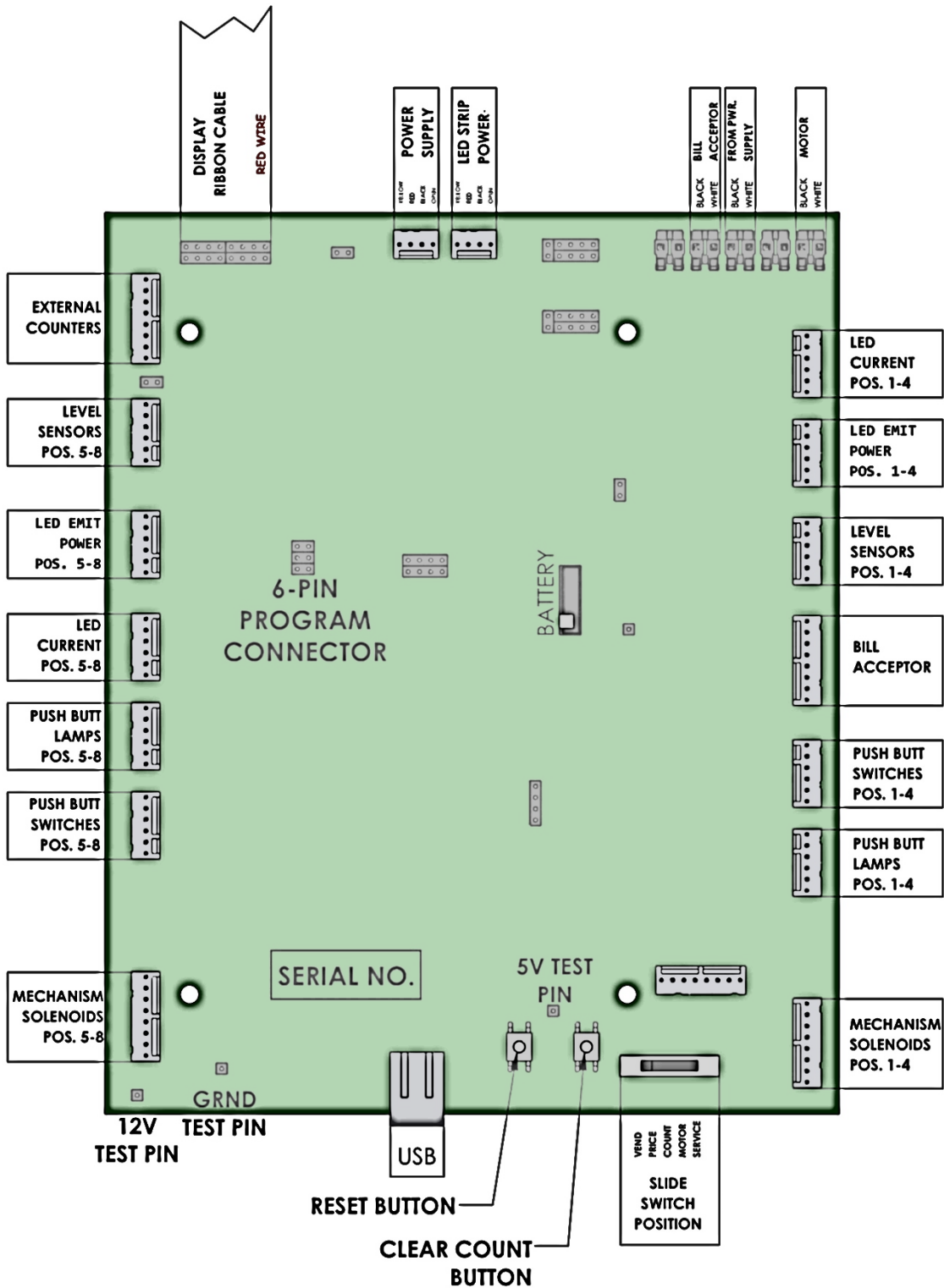

BILL ACCEPTOR PROBLEMS

IMPORTANT: DO NOT DISMANTLE THE BILL ACCEPTOR and attempt to repair the internal mechanism. This will void the warranty, and there will be charges for repairs.

COIN MECHANISM (OPTIONAL)

If your dispensing machine is equipped with a coin mechanism, it is designed to work with **QUARTERS ONLY** and other currency should not be tried in it.

The coin mechanism is mounted to the faceplate with 4 small carriage bolts. If it is necessary to remove it, the nuts to these are removed with a 6mm nut driver or socket from the rear of the machine.

The electrical connections are 2 spade lugs at the rear of the mechanism. **ONLY THE TOP 2 LUGS** are used, the bottom terminal is not connected.

In the event of a jam that the release lever in front won't clear, open the bill acceptor door of the machine and turn the power to the machine off. Next, locate the cylindrical spring at the top of the mechanism and slide it toward you until it is only on about 1/2 inch.

As you look at the right side of the mechanism, you will see a metal collar with a screw rising from it. Grasp this with your thumb and forefinger and remove the right side of the mechanism.

At this point, the coins that are stuck will be exposed and should be gently removed with the use of a toothpick or other slim object.

Near the rear of the mechanism on the left, there is a brightly polished metal plate on a pivot. Immediately above this plate is a slot going into the mechanism. With a toothpick or other slim (not sharp) object, clear this area of any coins or foreign matter that may be stuck there.

Re-assemble mechanism by returning the side of the mechanism to its former position and sliding the cylindrical spring away from you until it is firmly holding the side plate to the rest of the mechanism.

If the mechanism fails to give credit for quarters inserted, check to see that both of the top 2 terminals are connected to the wiring harness. If they are, it will be necessary to adjust the bend on the trip wire located at the bottom rear of the mechanism. With a pair of needle nose pliers, just bend the wire a little more sharply at the same place it is already bent. This should cure the problem.

PYRAMID BILL ACCEPTOR

Acceptor Diagnostics

Use the Diagnostic Pushbutton on the side of the acceptor (toward the rear) as shown.

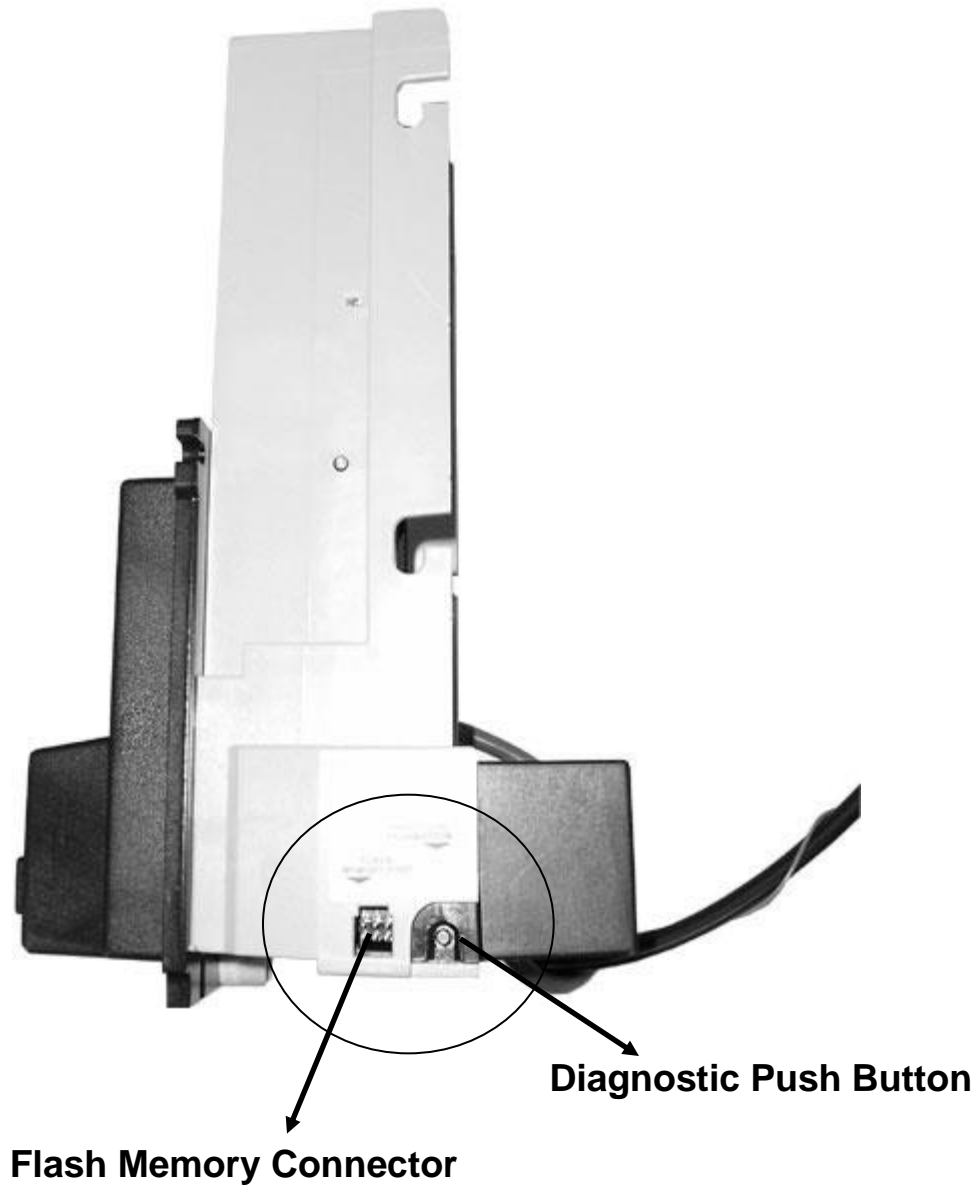

Front Bezel Lighting Flash Codes

The flash codes shown correspond to the Apex bill acceptor error. The acceptor will flash the error code, then wait 3 seconds and flash it again.

Flashing Code	Meaning of Flashing Code	Corrective Action
LED's always OFF	The acceptor has no power.	Check that power has been applied.
LED's always ON	No error exists – acceptor is OK.	None.
1 Flash	Something is in the bill path	Remove the cassette and Lower Sensor Plate to inspect for foreign objects. Clean if necessary.
2 Flashes	Something is obstructing the stacker.	Remove the cassette and Lower Sensor Plate to inspect for foreign objects. Clean if necessary.
3 Flashes	The cassette is full of currency.	Remove the cassette and empty it.
4 Flashes	The cassette has been removed	Replace the cassette.
5 Flashes	The acceptor is defective	Replace the acceptor.
6 Flashes	The acceptor is not enabled	Verify that the host has enabled the acceptor.
10 Flashes	Configuration Mode has been entered.	Configuration Card must be inserted into the acceptor or cycle power to the acceptor to exit this mode. See Configuration Section for details.

Removing the Cashbox

To remove the stacker, push back the Cashbox Latch toward the front of the acceptor. Then pull the Cashbox upward, and then pull back to remove.

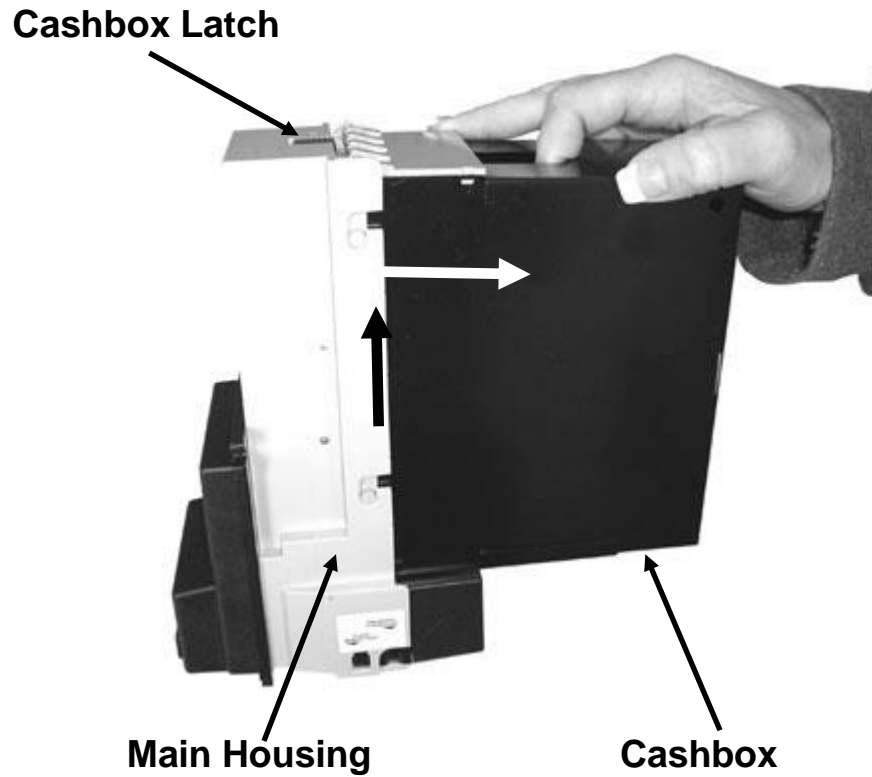

Installing the Cashbox

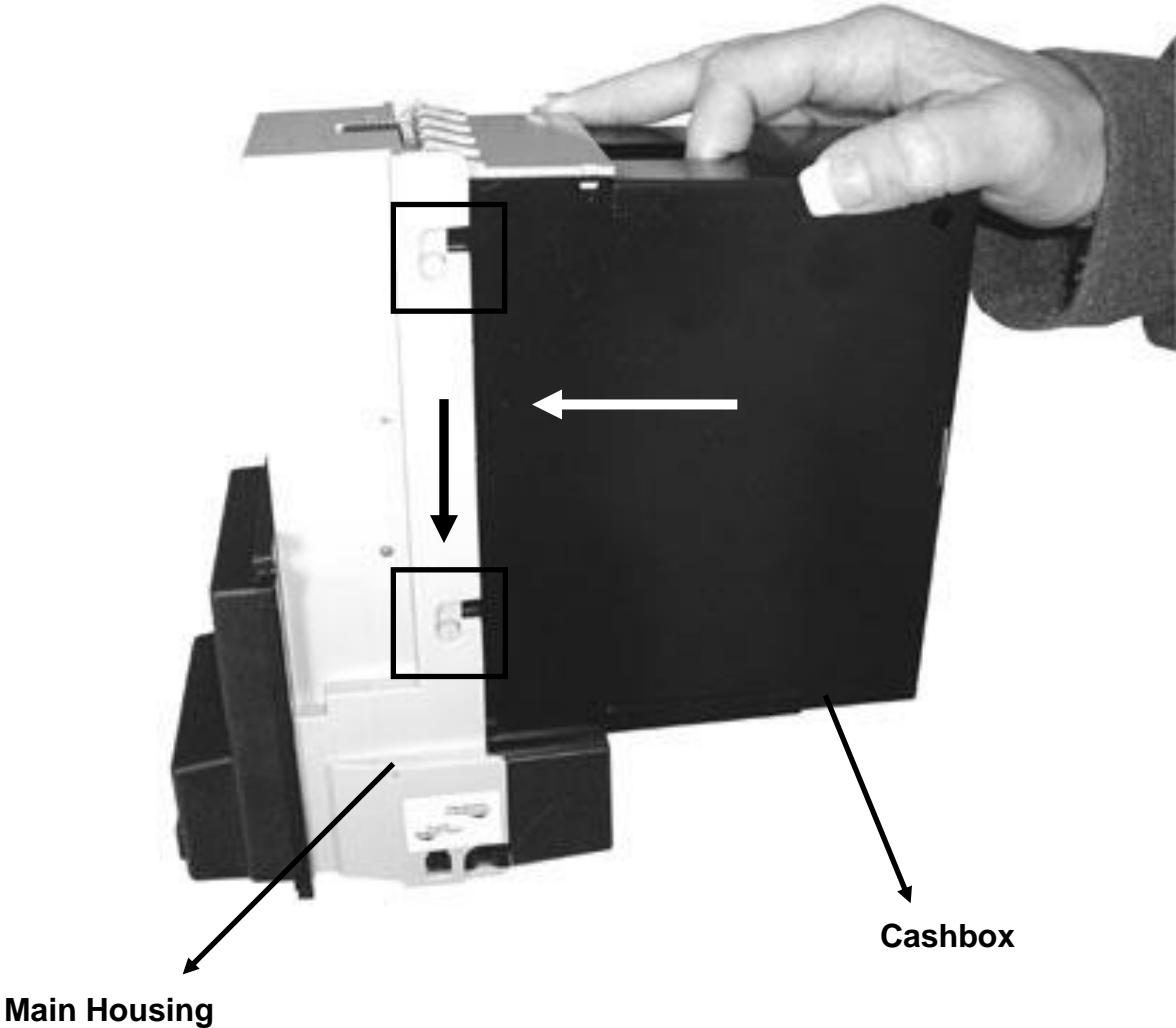

NOTE: WHEN INSTALLING THE CASHBOX MAKE SURE THE TABS ARE PUSHED FORWARD INTO THE SLOTS ON THE MAIN HOUSING AND THEN PUSH DOWN MAKING SURE THEY CLICK INTO PLACE. IF THE CASHBOX IS NOT PROPERLY INSTALLED THE BILL ACCEPTOR WILL NOT FUNCTION.

Removal of the Lower Sensor Plate

Removal of the Lower Sensor Plate is done by pressing the locking tab in and pulling the plate back. **NOTE:** Before removing the Lower Sensor Plate make sure you unplug the 18 pin connector from the other side of the bill acceptor. It is not shown in the picture.

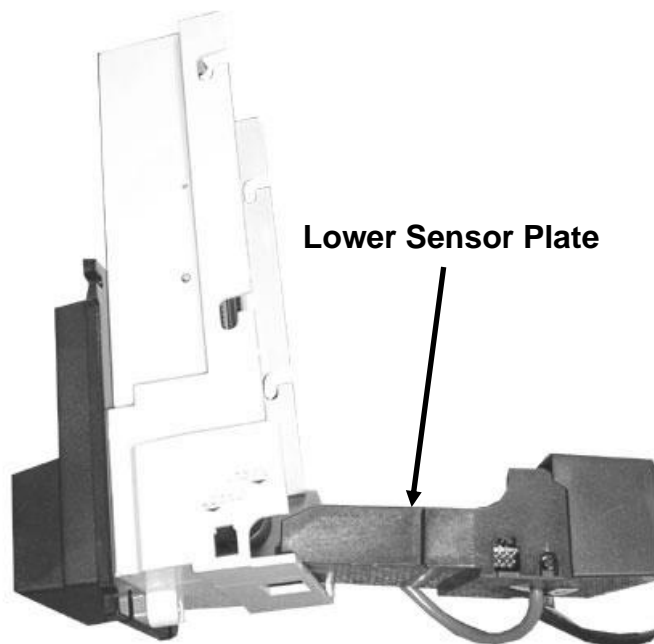
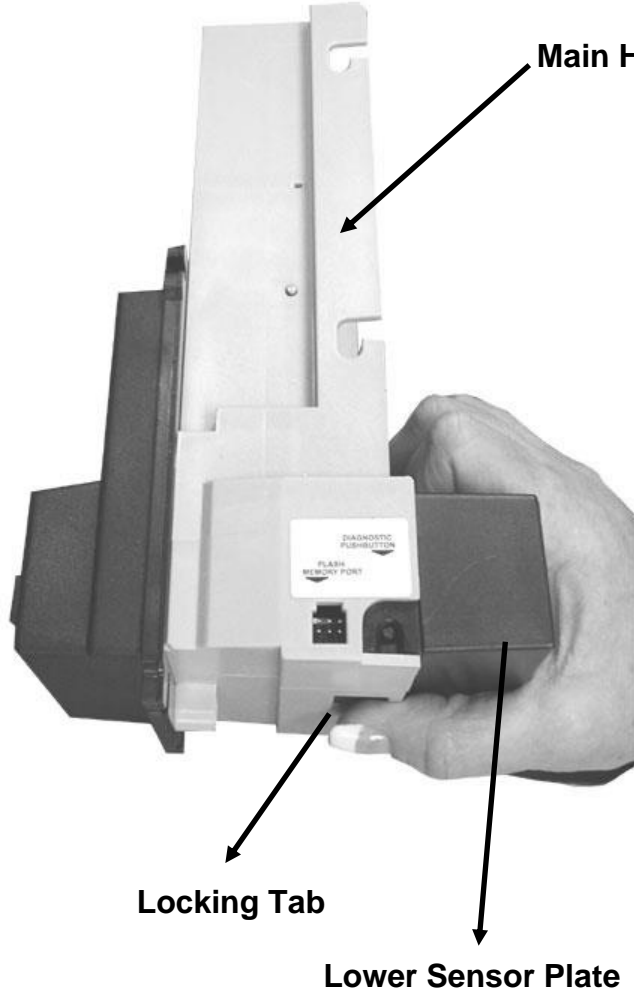



Technik Mfg., Inc.
1005 17th Street
Columbus, NE 68601
(800) 795-8251
(402) 564-3191
www.technikmfg.com

Instructions For The Technik Grandmaster Randomizer Key Part No. 311-513

These instructions describe the function and use of the Technik Randomizer Key with Technik Minnesota Grandmaster models utilizing firmware revision 111-032H or higher.

The Key allows changing the dispensing function models using 111-032H or higher firmware from random column dispensing to non-random dispensing and vice-versa. Once the machine is programmed for the desired mode and the Key is removed from the machine it will remain in that mode until reprogrammed again using the Key. The machine will remember its mode even when the power is off and its mode cannot be changed without use of a valid Technik Key.

Instructions For Use

To change the mode of a Minnesota Grandmaster perform the following steps:

1. Turn off the AC power of the Grandmaster to be changed.
2. Open the lower cabinet door of the machine and locate the 110-090 main circuit board located on the left side of the cabinet.
3. Plug the Key onto the connector marked "ICSP" near the center of the circuit board. Be careful to orient the Key in the direction shown and ensure that all six pins of the Key are lined up on the ICSP connector.



4. Turn on the machine's AC power.

