

THE MASTER

SET UP AND OPERATION MANUAL

YOUR MACHINE SERIAL NUMBER: _____



1005 17th Street
Columbus, NE 68601
Service Dept. 1-800-795-8251
serv@technikmfg.com

THE MASTER 4 SET UP AND OPERATION MANUAL

TABLE OF CONTENTS

SAFETY CONSIDERATIONS	2
UNPACKING	2
MACHINE MOUNTING	3
AUTOMATIC SEQUENCING	3
MODES OF OPERATION	4
INSTALLING PUSHBUTTONS	5
PRICING MACHINE	6
CARD THICKNESS ADJUSTMENT	7
LOADING TICKETS	8
CHECKING COUNTS	9
SPECIAL FEATURES	9
INITIALIZING PROCEDURE	10
RESET PROCEDURE	10
TROUBLESHOOTING	
ERROR CODES	11
ERROR CODE FLOW CHARTS	12--21
CARDS JAM OR HESITATE	22
CARDS JAM OR HESITATE FLOW CHART	22
ODD COUNTS AND DISPENSING	23
CARDS NOT DISPENSING FLOW CHART	23
FUSE BLOWN	24
NO POWER	24
POWER INTERRUPTIONS	24
NO POWER FLOW CHART	25
DOOR DOES NOT CLOSE PROPERLY	26
REGULAR MAINTENANCE	26
SERIAL NUMBER LOCATION	26
FACTORY SERVICE	26
CONTROL BOARD	27
PYRAMID BILL ACCEPTOR	28-32
COIN MECHANISM	33
SERVICE LOG SHEET	34
MASTER 4 MACHINE LOG SHEET	35

SAFETY CONSIDERATIONS

1. Unplug the machine when servicing – failure to do this could cause serious injury.
2. If the supply cord is damaged, the manufacturer, its service agent, or a similarly qualified person must replace it.
3. Permanent bypass of any safety switches may cause serious injury.
4. Refer to the “**Machine Mounting**” section of the manual for proper installation instructions.
5. A three prong grounded outlet must be used to power this machine.
6. Do not overload power circuits.
7. Do not use extension cords to run power to this machine.

UNPACKING

When the machine is received, it should be carefully unpacked and checked closely for any possible damage. If a freight company is involved, and there is damage, please notify them immediately. They will need to thoroughly inspect the damage and fill out a report. Please **do not** install the machine until this has been done.

Please remove and save packing material for later use.

The following items are packed in the carton:

<u>QUANTITY</u>	<u>DESCRIPTION</u>
1	PULL TAB VENDING MACHINE
2	¼-20 x 1” Hex Bolts
1	Hex Key Wrench
4	Short Weights
4	Long Weights
4	Three-tab adaptors
4	Clear pushbutton covers
4	White Inside Pushbutton Backs
1	3 AMP fuse
4	\$.25 Currency legends
4	\$.50 Currency legends
4	\$1.00 Currency legends
4	\$2.00 Currency legends
2	Threaded Knobs
2	Keys
1	Card display holder
1	Machine manual
1	Warranty certificate

*If the machine is equipped with a modem, an alarm, or a printer an Options Manual will be included as well.

MOUNTING THE MACHINE TO THE OPTIONAL BASE

If you have purchased a base, read the instructions listed below which describe the process of mounting the machine to the base.

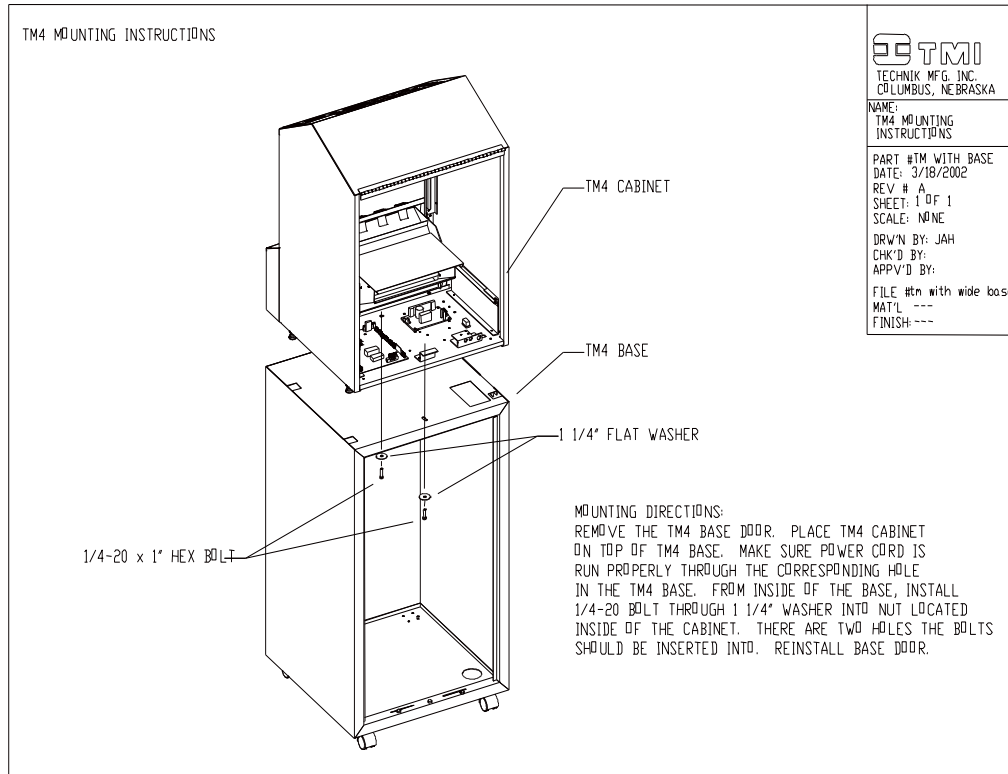

AUTOMATIC SEQUENCING

When the machine is first turned on, it will start its automatic sequencing. The sequence starts with three short audio “beeps.” The LCD will display important information (software version information, and the number of columns it has been initialized for). The machine will cycle each row’s solenoid and pushbutton light at the same time. Each row should “lift”, each light should light. This automatic sequencing is to be used as an aid to ensure that the electronics and moving parts are working properly. The machine will begin its normal attract mode after the automatic sequencing is completed.

MODES OF OPERATION

To change modes of operation use the selector switch located on the control board.

VEND MODE: This mode is what the machine should be in during normal operation.

PRICE MODE: This mode is used to price the individual columns.

COUNT MODE: This mode is used to check and clear accounting information.

MOTOR MODE: This mode is used to count inventory, clear a jammed card, adjust card thickness, and troubleshooting.

SERVICE MODE: This mode is used for assisting in troubleshooting and adjustments. All normal vend mode functions are available except money accepted and cards dispensed are not recorded into the accounting information. When in service mode, the audible alarm will sound briefly every 15 seconds to serve as a reminder that you are in the service mode.

SERVICE NOTE: If your machine has a CSA (Canadian Standards Association) sticker on the side of the machine the machine meets CSA standards. If your machine meets CSA standards it is equipped with a motor interlock switch (located inside the product compartment). The motor interlock switch disables the motor anytime the product door is opened. When servicing this product you may have to bypass this switch – please be aware of moving parts as they may cause injury. Do not permanently bypass any safety switches.

INSTALLING PUSHBUTTONS

The pushbutton assembly includes the clear top cover, currency legend, the white plastic back, and the pushbutton itself. Place the white back on the machine pushbutton. Insert the currency legend into the clear cover. Push the clear cover onto the machine pushbutton and push until it snaps on, one edge at a time. To remove the cover, use a thin screwdriver to pry it loose between the clear cover and the outer shell. Note the following illustrations:

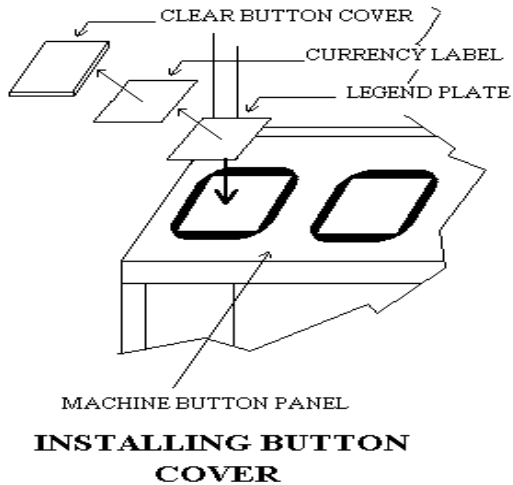

REMOVING BUTTON COVER

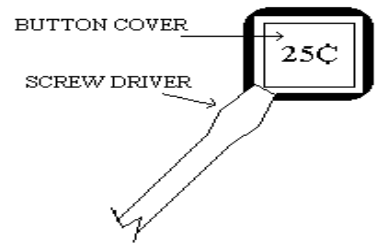

PLACE THE SCREW DRIVER AT THE EDGE OF THE BUTTON COVER AND TWIST THE DRIVER UP. REPEAT THIS FOR THE REMAINING EDGES.

If bulb burns out call the service number on the front of this manual or on the label placed inside your machine.

IMPORTANT: BE SURE TO GO THROUGH THE **“PRICING THE MACHINE”** SECTION OF THIS MANUAL AFTER CHANGING THE **CURRENCY LABELS!!!**

PRICING THE MACHINE

You are now ready to set the column's prices. As you are facing the back of the machine, you will see the control board. Slide the switch one position to the right to the **"PRICE"** position. Note the diagram below for control board location and where the switch is located on the board.

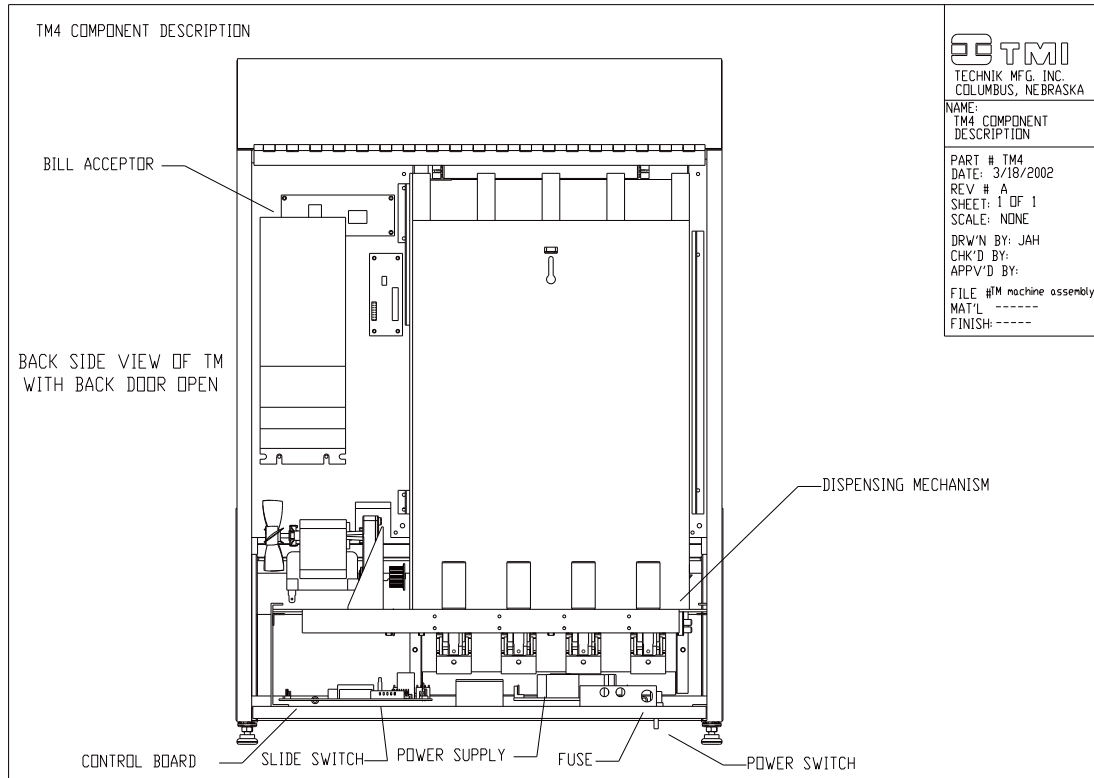

Notice the display on the front of the machine should now read **"Price Column A."** Also notice that column **"A"** pushbutton light is on. The second line of the credit display is indicating the current price of column **"A"**. Press the column **"A"** pushbutton to change to your required price. Once the proper price is displayed, the row is programmed for that amount and pressing the **"ALL"** pushbutton will advance to column **"B"**. The display will now read **"Price Column B."** Press the column **"B"** pushbutton to set that row to the desired price. Repeat the above steps to price the remaining columns.

Once you have programmed all rows, return the switch on the control board back to the **"VEND"** position.

CARD THICKNESS ADJUSTMENT

FOR 20 TO 30 MIL THICK CARD

1. With a hex head wrench, turn the adjustment screw on the dispensing mechanism counter-clockwise until a card will not pass the adjustment mechanism.
2. To make a "test card" place 2 pieces of clear tape or 1 piece of electrical tape as shown below.
3. Place "test card"; tape first, in the bottom of the column you wish to adjust.

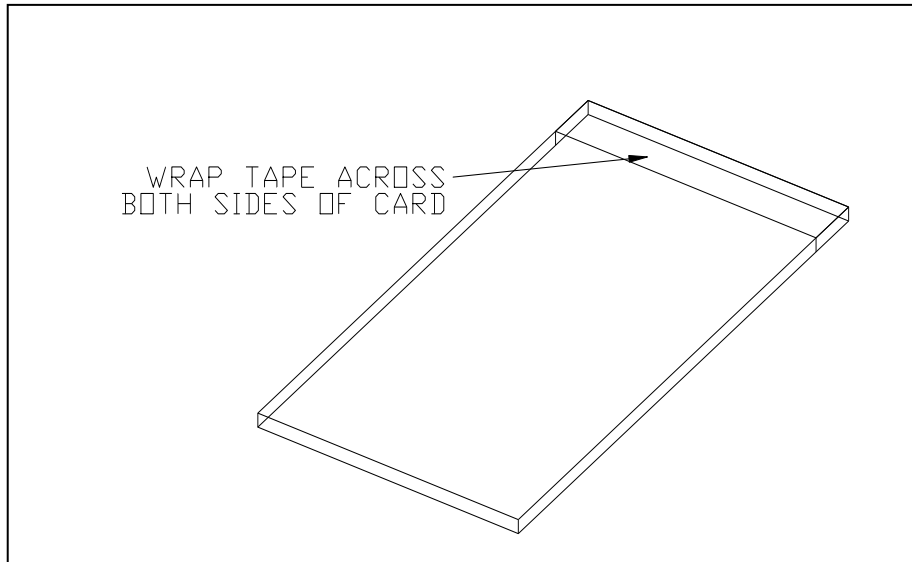

4. Place the adjustment weight on top of the card.
5. Add some money to the machine.

BEFORE GOING ANY FURTHER, READ THE INSTRUCTIONS BELOW!!!

6. Place the hex head wrench into the adjustment screw.
7. With the door open, dispense a card. But at the same time you are dispensing a card, turn the adjustment screw clockwise until a card is dispensed. It may take a few tries before a card is dispensed.
8. Once a card is dispensed, then that column is set.
9. Follow the procedure on the other columns.

FOR 10 MIL CARDS

1. Follow the same procedure above, but instead use one piece of clear tape on the leading edge of the card.

LOADING TICKETS

You are now ready to start loading the tickets. Tickets can be loaded face up or down. If there is significant bow, the tickets are to be loaded “belly” down.

Please note: You must place a weight on each of the rows to insure proper card dispensing of the entire row.

If you are dispensing three-tab tickets, you may need to use the 3-tab adapters. The 3-tab adapter is used to keep shorter tickets close to the front of the mechanism. This ensures your machine will operate reliably.

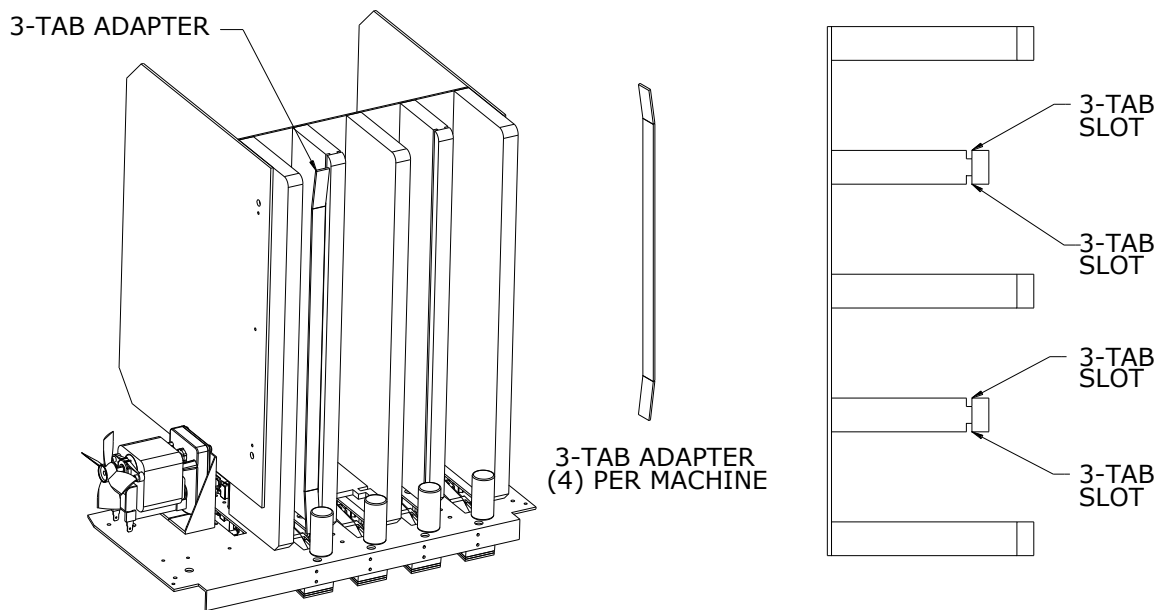

The 3-tab adapter is a piece of plastic that has a slight bend at both ends. Each column has a “3-tab slot”. This is where the 3-tab adapter is to be installed. To install the adapter slide the bottom end of the adapter into the “3-tab slot” then using slight pressure insert the rest of the plastic strip.

Now that the tickets are loaded and the slide switch is in the “**VEND**” position, you may place money in the machine to check its operation. Try \$1.00, \$5.00, \$10.00, and \$20.00 bills to make sure the bill acceptor is giving proper credits; then begin to dispense cards row by row. As you begin to dispense tickets, make sure they are coming out of each row in the proper denominations and the row is functioning properly.

CHECKING THE COUNTS

The Master 4 has “**re-settable**” and “**non re-settable**” accounting information. When the slide switch is on “**COUNT**”, this information can be viewed on the display on the front of the machine.

The “**ALL**” button is used to view the counts for cash and cards. The “**ALL**” button will go through all the information of total and period counts. The cash and cards titled “**PERIOD**” are re-settable counts. The re-settable counts can be cleared by pressing the “**CLEAR**” button. The cash and cards titled “**TOTAL**” are non re-settable. The non-resettable counts will keep a lifetime total until the machine is re-initialized.

Returning the selector knob to “**VEND**” will set the machine to normal operations.

SPECIAL FEATURES

The Master 4 has the following feature so that it may be easier to determine the remaining inventory cycle count.

1) Inventory: The Master 4 will electronically count the remaining tickets in each column.

- Place the selector switch in the **Motor/Inventory** position. The motor will run constantly.
- To count the remaining tickets in a column, press the pushbutton for that column. The machine will then dispense the tickets from that column until it is empty. With each ticket dispensed, the machine will increment the count on the credit display on the front of the machine.
- To stop the column from dispensing before it is empty, press that push button for one second. Note that the tickets will stop dispensing and two counts will be on the display. The first number and the number in parenthesis will indicate the number of tickets dispensed. The first count will reset to zero when the pushbutton is pressed again. The count in parentheses will continue counting.

2) Credit-Erase: This feature will clear the display of any unused credits.

Players may mistakenly not use all their credits and this feature will clear those credits. The machine will return to its normal attract mode when the unused credits have cleared. This credit erase feature takes approximately 6 minutes. See “**Checking the Count**” to view this information.

***This feature is not available on New Jersey machines.**

INITIALIZING PROCEDURE

This procedure allows automatic reprogramming of the entire system. All pricing and re-settable counts may be lost.

This procedure is as follows:

1. Position the slide switch to the “**PRICE**” position.
2. Hold down the “**CLEAR**” button
3. Turn the machine off and back on.
4. Wait for the audible signals (beeps)
5. Release the “**CLEAR**” button

Once the automatic sequencing is completed, the rows will need to be programmed for the correct prices. After the programming is completed, return the slide switch to “**VEND.**”

RESET PROCEDURE

Once a row malfunctions, it automatically shuts down and the light goes out. The other rows will still be functional as long as their light is on. Once a card jam is cleared, the machine must be reset. There is a switch concealed under the machine near where the cord enters the steel cabinet. Simply move this toggle switch to the off position for about three seconds, and then back on. The machine is reset. This will re-light the button on that row. The machine has a battery backup for the memory, so shutting the power off and on again does not cause the machine to lose its count or program.

TROUBLE SHOOTING

WARNING!!! WARNING!!! WARNING!!! WARNING!!! WARNING!!!

ERROR CODES

ALWAYS UNPLUG THE MACHINE PRIOR TO SERVICING THE MACHINE

- E-02** This means that a jumper on the board is not installed properly, or the counters are not connected. Contact a service technician for assistance.
- E-04** This means that a power interruption occurred while the machine was dispensing a ticket. A ticket will be dispensed as the machine is turned off, then back on. To reset, push the **“CLEAR”** button on the control board.
- E-10** This means that the machine has lost its memory and the row denominations will default to the default pricing and counts will be cleared. The control board needs to be re-initialized. See the **“Initializing Procedure”** section of this manual.
- E-11** This means the bill acceptor pulse was too long in duration. Turn the machine off, and then back on. This error code will clear itself.
- E-12** This means the bill acceptor pulse was too short in duration. Turn the machine off, and then back on. This error code will clear itself.
- E-13** This means the selected ticket took too long to dispense. Remove the ticket from that row. To clear, turn the machine off, and then back on.
- E-14** This means that an unexpected ticket was sensed in another row, other than the selected row. The unit will **ONLY** operate in the **“MOTOR”** mode. To remove the unexpected ticket, either physically remove it or move the selector switch on the control board to **“MOTOR”**. The motor will run for 1.5 seconds and then the ticket will be dispensed. To clear the **E-14** error code, turn the machine off, and then back on. **Note: The control board is programmed with a sensor diagnostic and can be viewed if E-14 error codes are frequent. With an E-14 error code displayed and the slide switch in “VEND”, press the “CLEAR” button on the main circuit board. The pushbutton light that is lit is indicating that column is causing the error code.**
- E-15** This means that the non re-settable counters have been corrupted due to loss of memory. It is possible to view the corrupted counters by using the procedure under E-10. While E-15 is displayed and in the **“PRICE”** mode, press the **“CLEAR”** button to clear the error code and the machine will reset itself. Please note that the counts on the non re-settable counters will be zero after the clearing procedure

ERROR CODES FLOW CHART

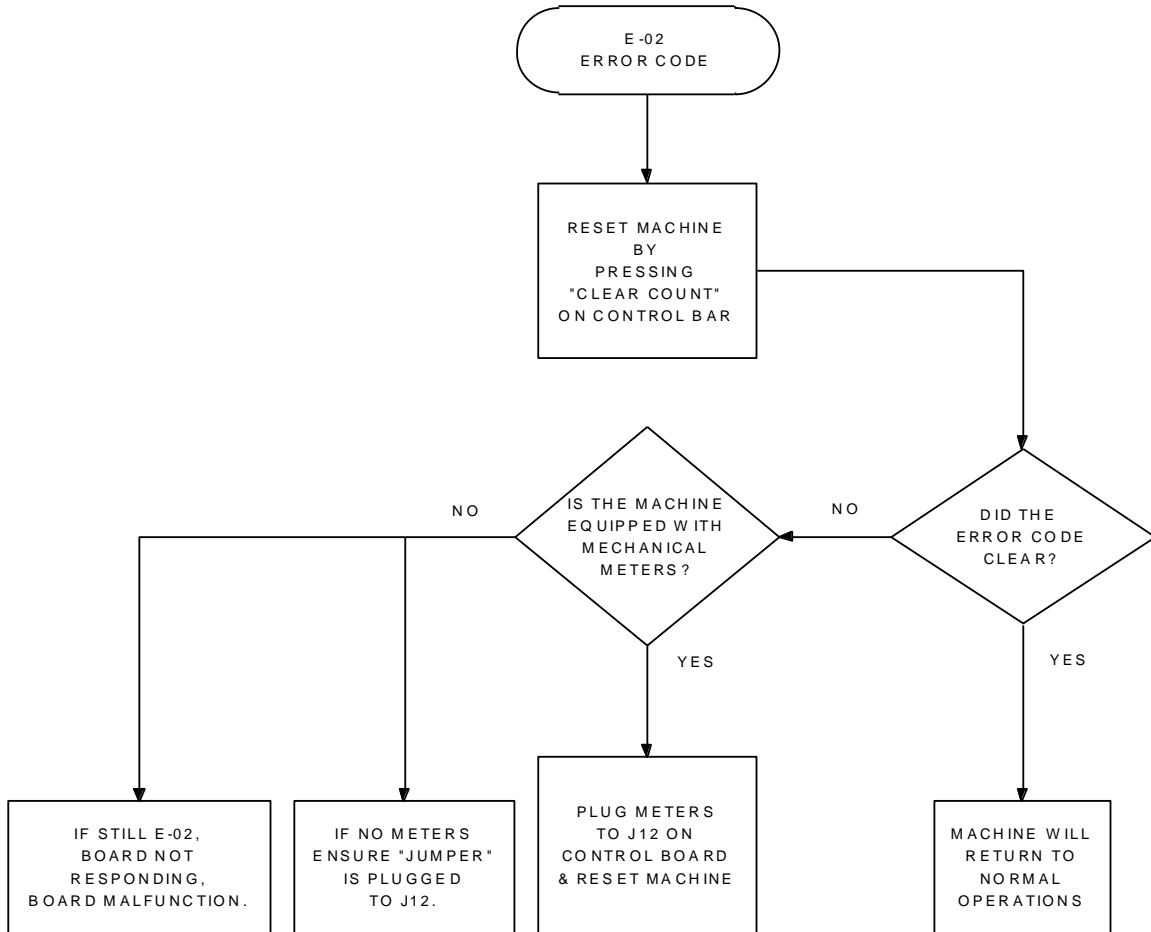

ERROR CODES FLOW CHART

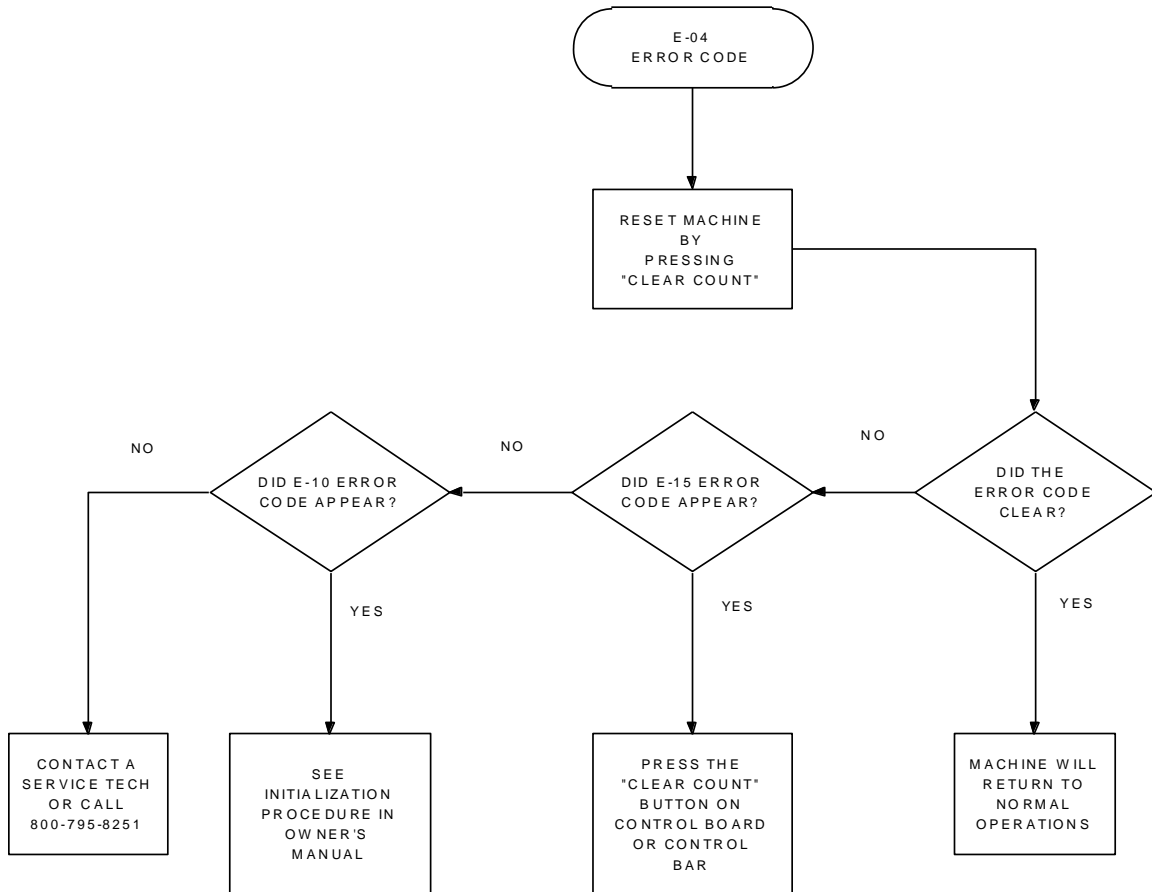

ERROR CODES FLOW CHART

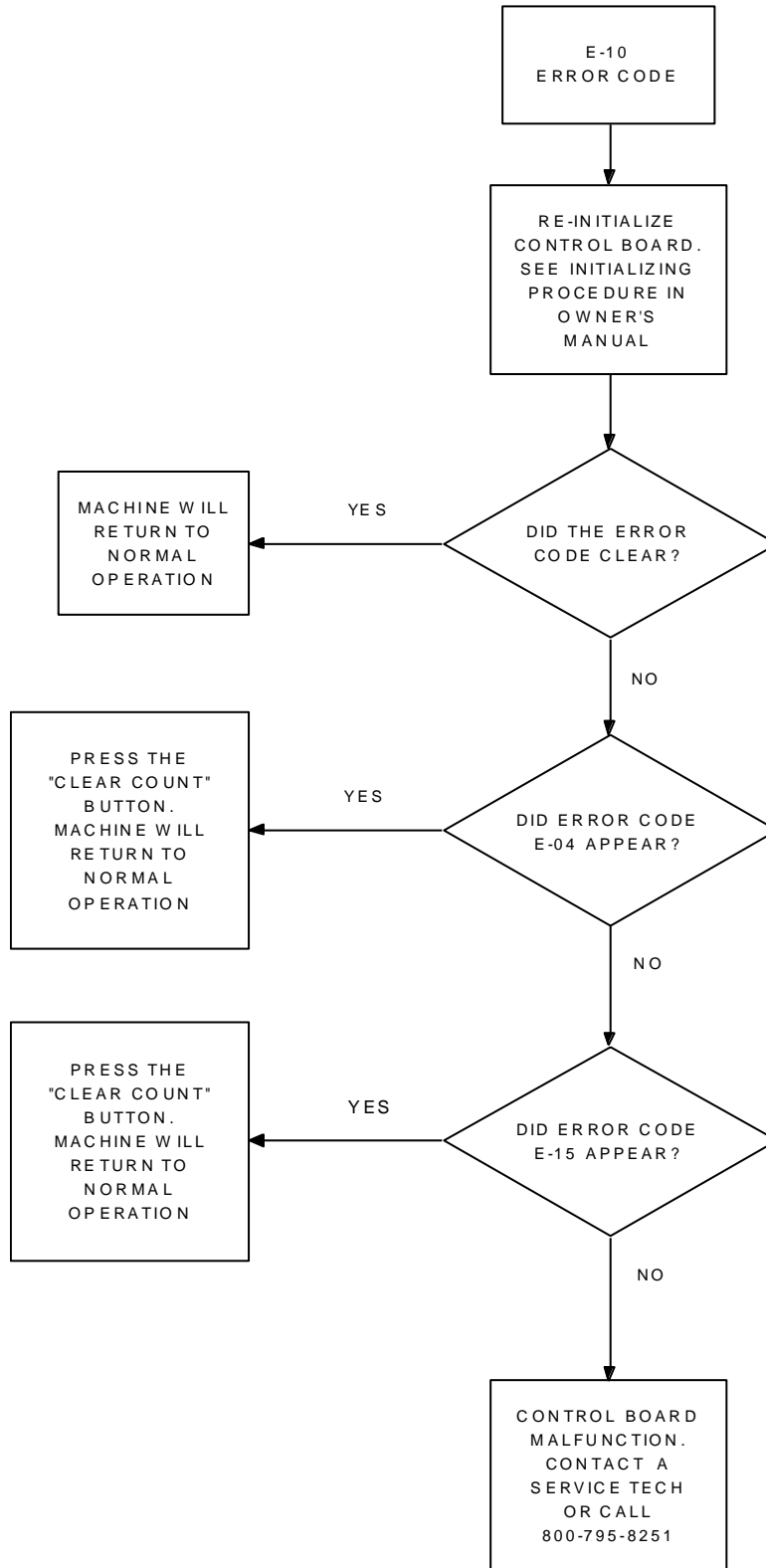

ERROR CODE FLOW CHART FOR COINCO BILL ACCEPTOR

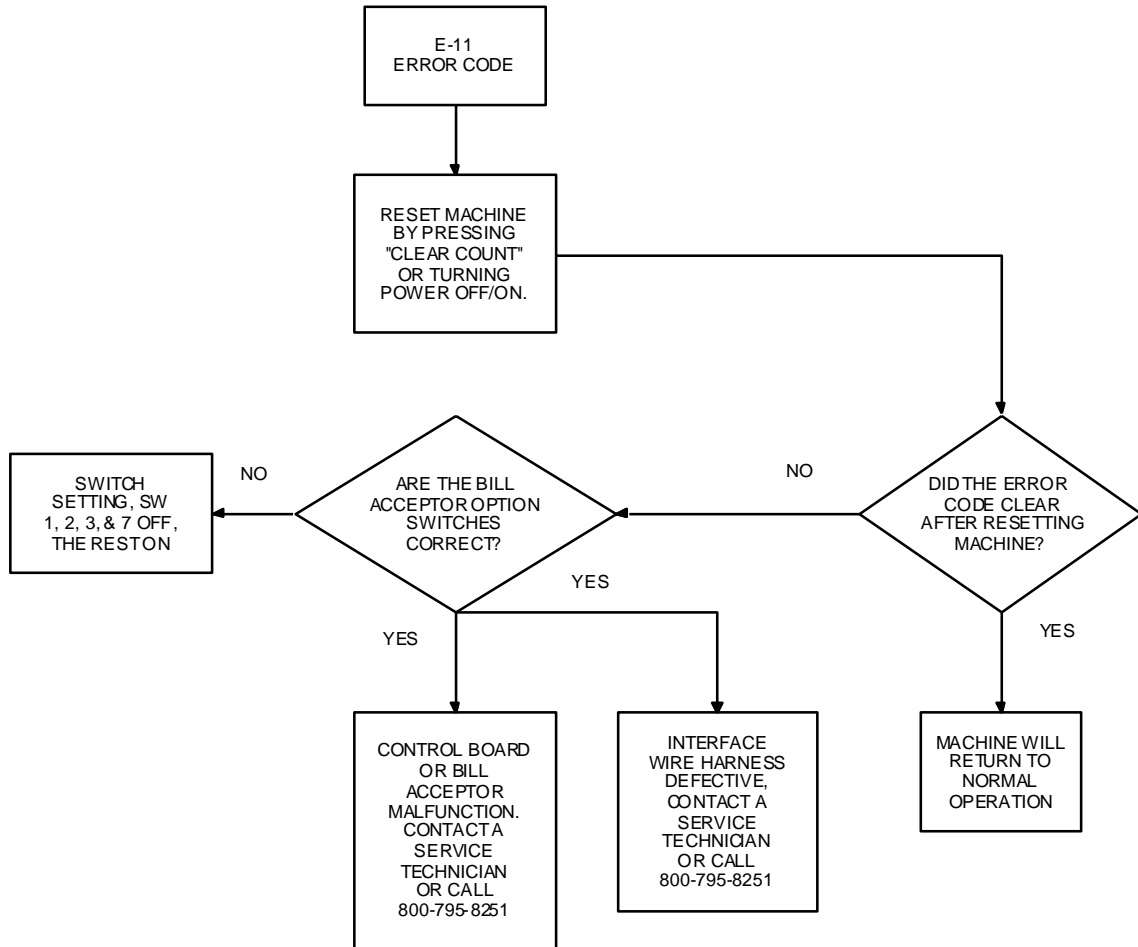

ERROR CODE FLOW CHART FOR PYRAMID BILL ACCEPTOR

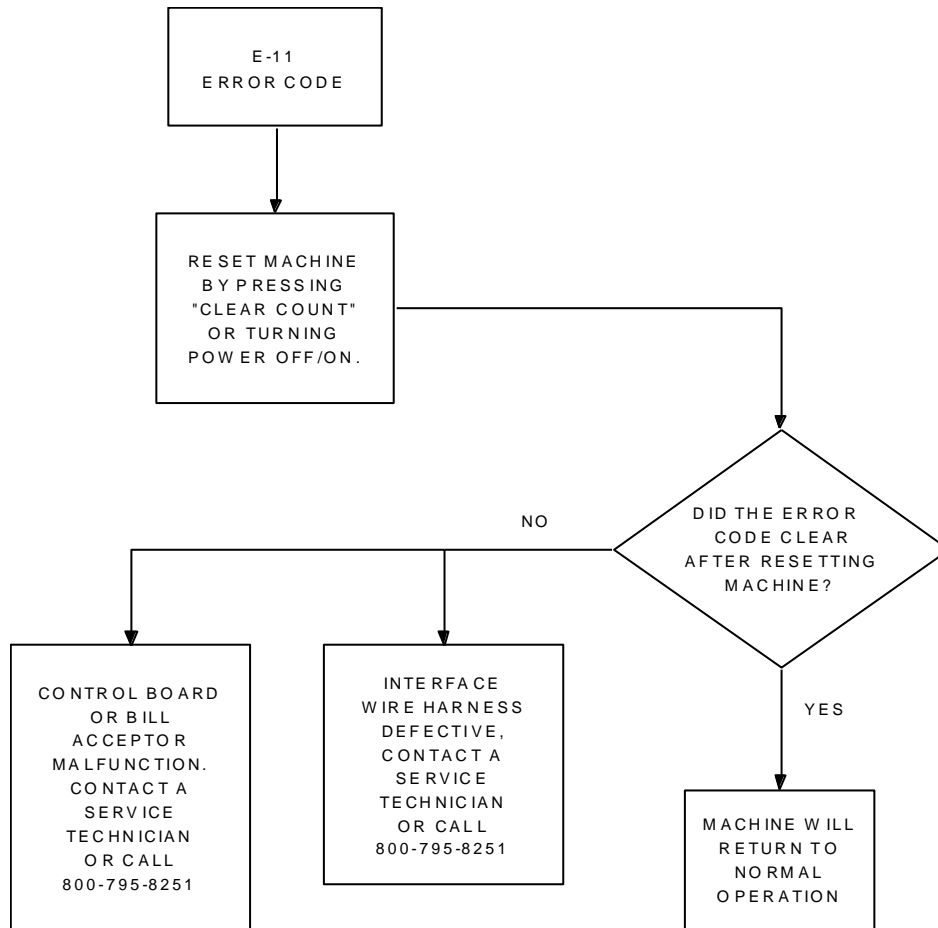

ERROR CODES FLOW CHART FOR COINCO BILL ACCEPTOR

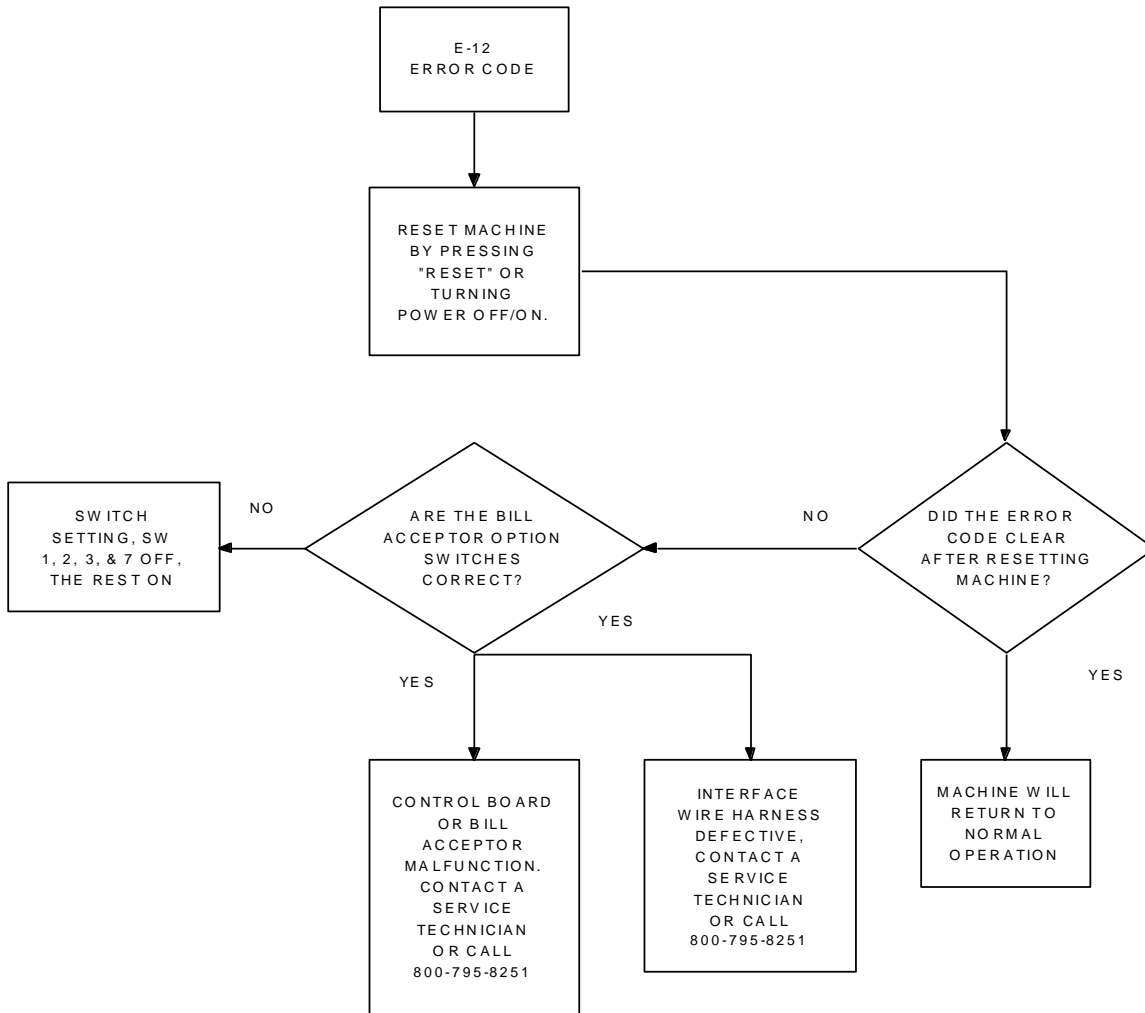

ERROR CODE FLOW CHART FOR PYRAMID BILL ACCEPTOR

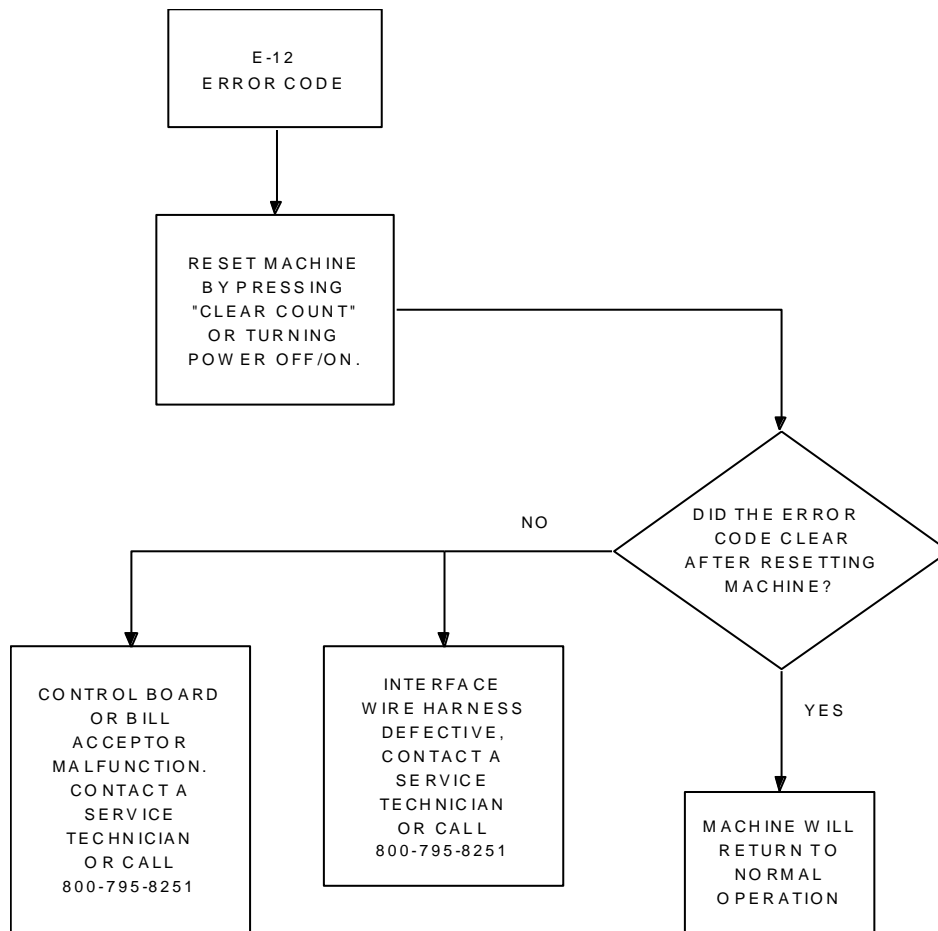

ERROR CODES FLOW CHART

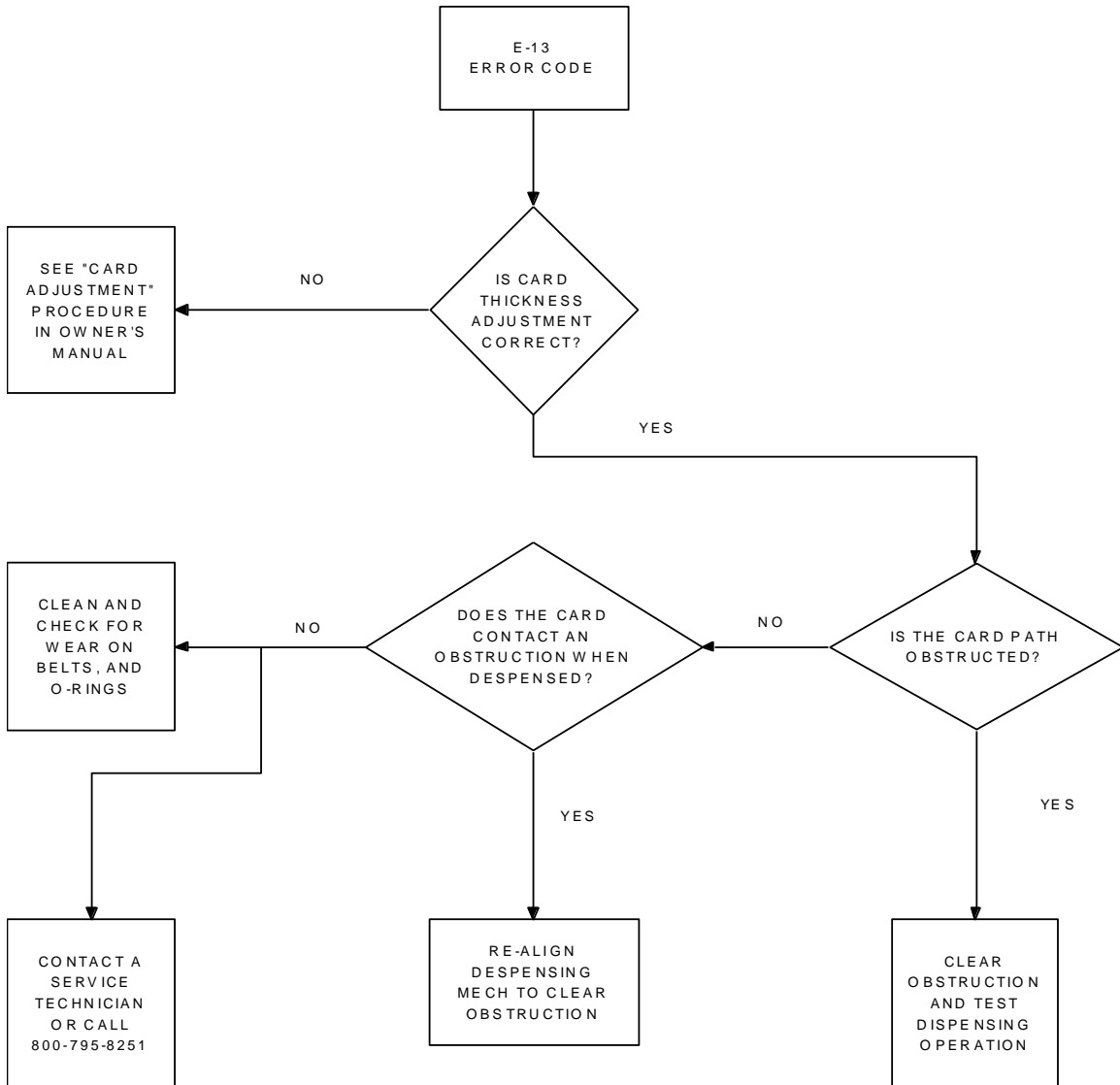

ERROR CODES FLOW CHART

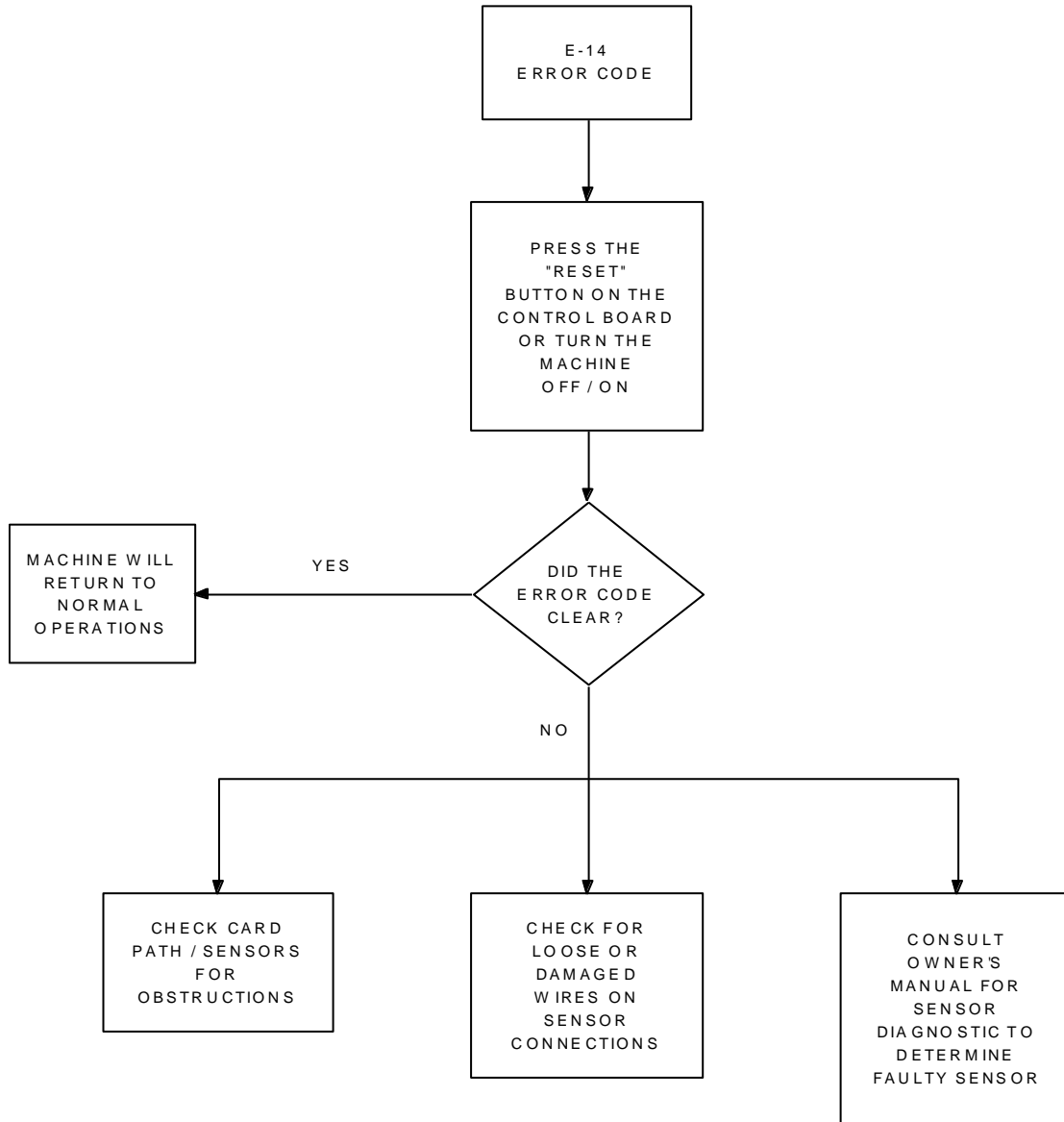

ERROR CODES FLOW CHART

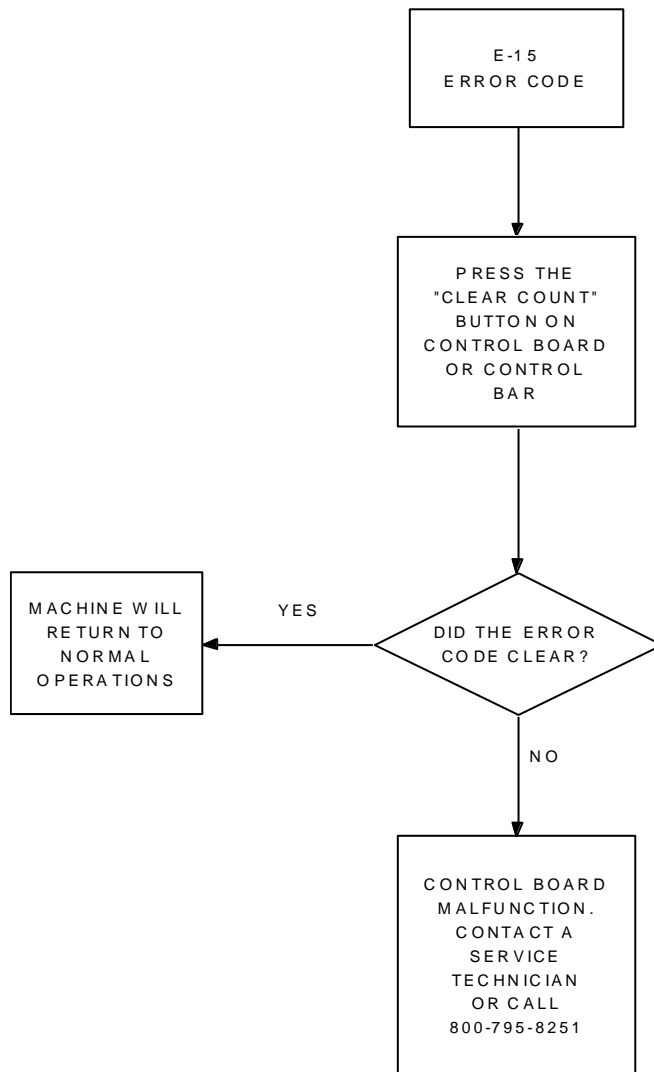

CARDS JAM OR HESITATE

- 1) Cards may be too thick or thin. Or the card gap may need to be adjusted. See “**Card Thickness Adjustment**”.
- 2) Cards may be excessively warped or bowed. Call your supplier.
- 3) Cards may be glued together. The machine is designed not to accept 2 cards at once. Again, call your supplier. Also, fanning the cards prior to loading may solve this problem.
- 4) Cards may be damaged. Remove damaged cards and try again.
- 5) A loose roller may cause this problem. A loose setscrew that is intended to lock the rollers to the shaft can cause this.

CARDS JAMMING OR HESITATING FLOW CHART

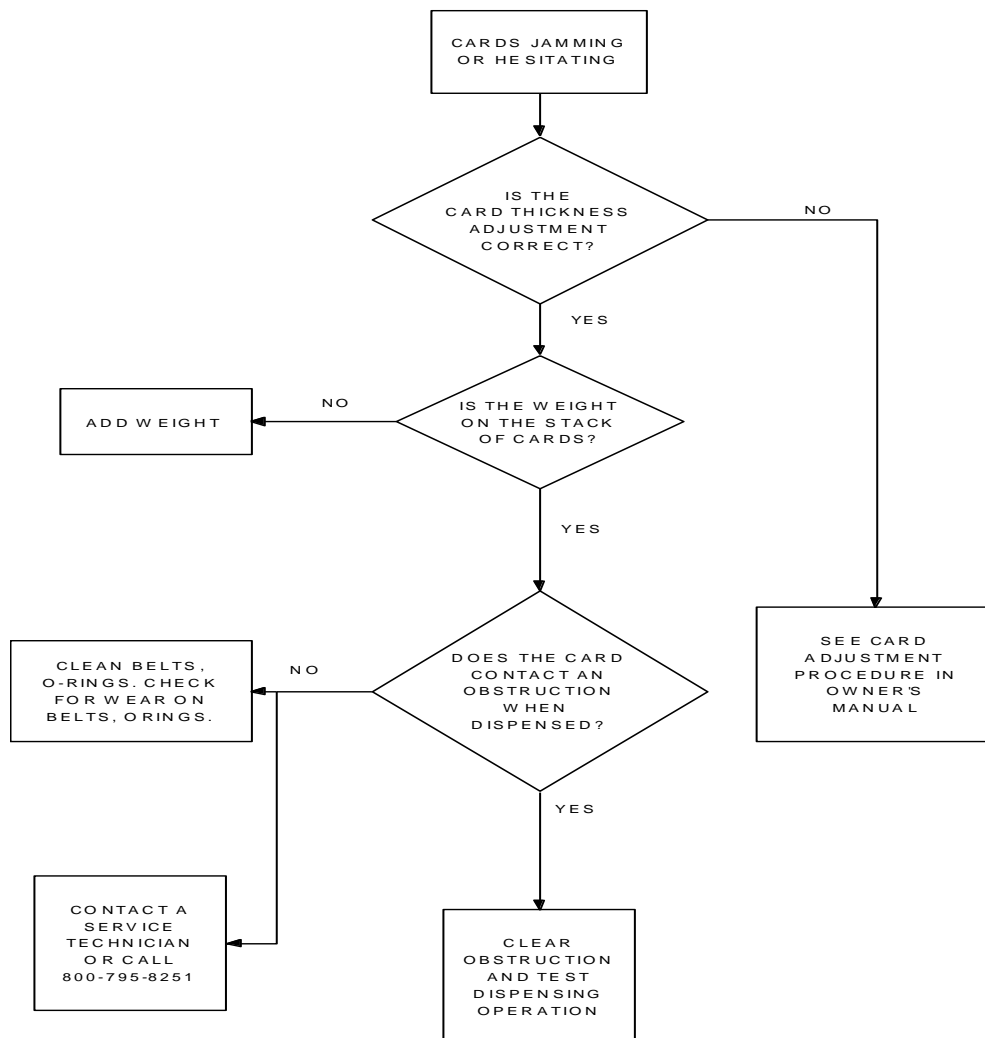

ODD COUNTS AND DISPENSING

- 1) Static electricity is a major contributor to this and all other electronic equipment. You **MUST** use a 3-prong grounded receptacle.
- 2) At times (mostly in the winter), strange static problems can occur. It may be necessary to spray the carpet area around the machine with a diluted mixture (10:1) of Downy fabric softener and water once every two weeks. **DO NOT SPRAY MACHINE.**
- 3) Total re-programming may be needed. See the “**INITIALIZING PROCEDURE**”. This procedure erases all settings and re-settable counts. The machine must now be re-programmed.
- 4) Low voltage causes many electronic problems. If your unit is plugged into an extension cord, or is on the same line with refrigeration equipment, etc., the 115-volt supply may be less than 100 volts. Have an electrician check the voltage supplied to the machine and repair as needed.
- 5) The sensor may be dirty. One sensor is built into each track just beyond the drive rollers. Should the lower sensor get filled with card shavings, it may not be able to sense. Simply blow air or use a cotton swab to clean this area.

CARDS NOT DISPENSING

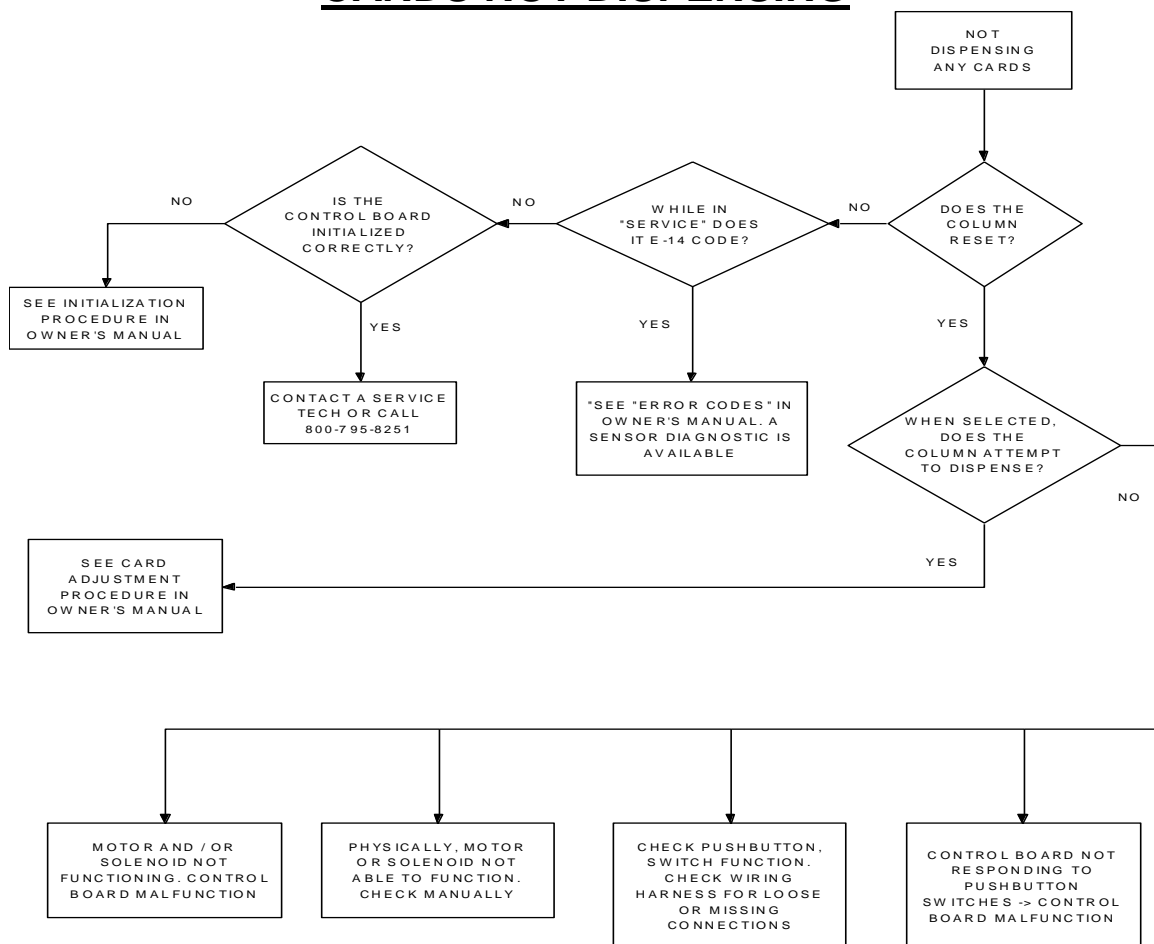

FUSE BLOWN

If the machine shuts down and nothing works, check the fuse. The machine uses a 3 AMP fuse, AGC fuse.

NO POWER

A toggle switch which turns the machine power on and off is located on the underside of the machine, close to the power cord. This switch can be used as a means of resetting the machine without opening the cabinet.

POWER INTERRUPTION

It is possible that if power dies exactly at the moment a card is being delivered, the card will stop and not be delivered until power is returned and the motor is ran. The machine recognizes this situation by displaying an **E-04** error code. The machine will not operate until reset. This single ticket that was dispensed will not have been counted, nor will it have been deducted from the credit. Two possibilities then exist:

- 1)** The customer removes and plays the ticket after power has been restored. This is not a problem since the ticket has been paid for. The person at the location realizes this is due to the E-04 error code and dispenses one additional ticket from that column and returns it to the stack. This procedure corrects the ticket count and the dollar count.
- 2)** The person at the location can simply return the ticket to the stack after it has been dispensed and allow the customer to play. This procedure also corrects the ticket and dollar counts.

NO POWER FLOW CHART

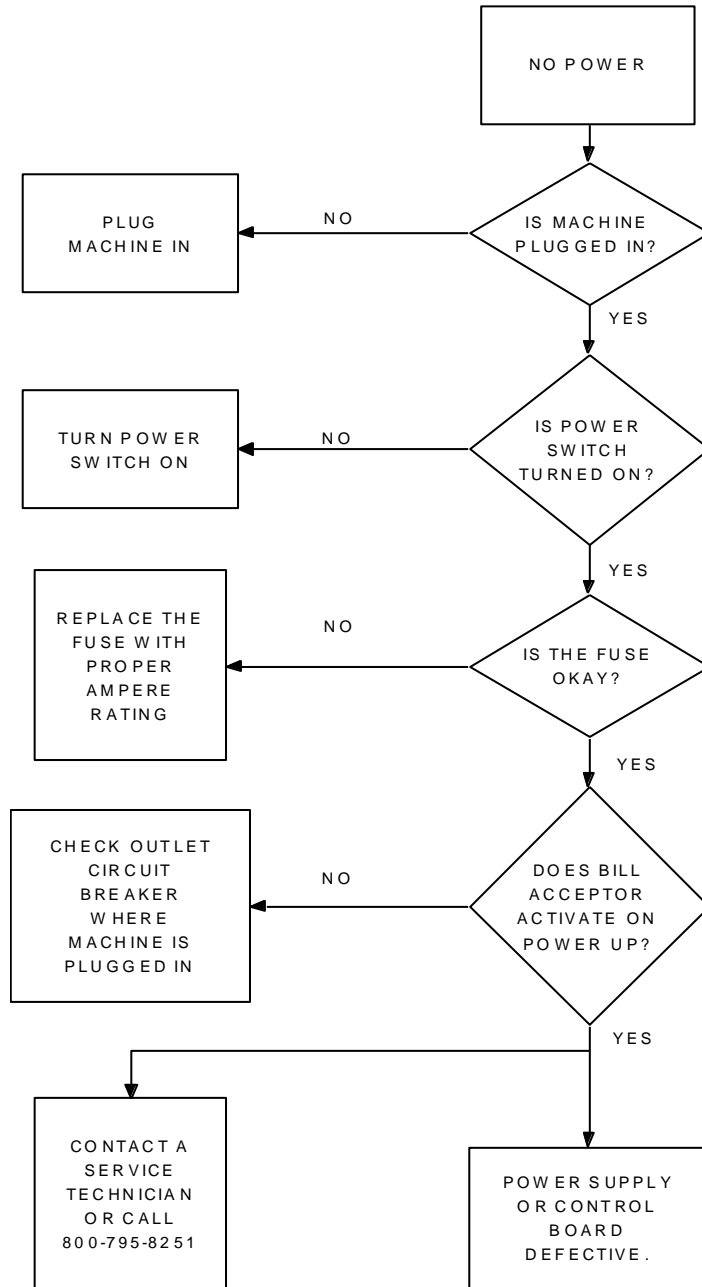

DOOR DOES NOT CLOSE PROPERLY

The machine is adjusted to work on a level surface. It may require adjustment of one or more of the four adjustable feet under the machine.

REGULAR MAINTENANCE

- 1) Clean belts as needed with water.
- 2) Clean windows as desired. Cleaning of windows should be performed with care. The front window is bulletproof but it will still scratch very easily. Use a soft cloth with plastic cleaner. **DO NOT use a dry towel of any type.**
- 3) Clean the bill acceptor as needed.
- 4) Lubrication should **NOT** be necessary.

SERIAL NUMBER LOCATIONS

There are three serial number locations on your machine. One of the serial number labels is visible through the front window. It is located on the inside left side of the cabinet, up near the peak of the roof. The second location is in the lower left side of the opened door. The third location is on the front of this manual.

FACTORY SERVICE

Service is available at your fingertips. Simply call the number shown on the front of this book or on the label placed inside your machine.

WHEN CALLING FOR SERVICE, PLEASE HAVE YOUR MACHINE SERIAL NUMBER READY.

CONTROL BOARD

REVISION F BOARD LAYOUT

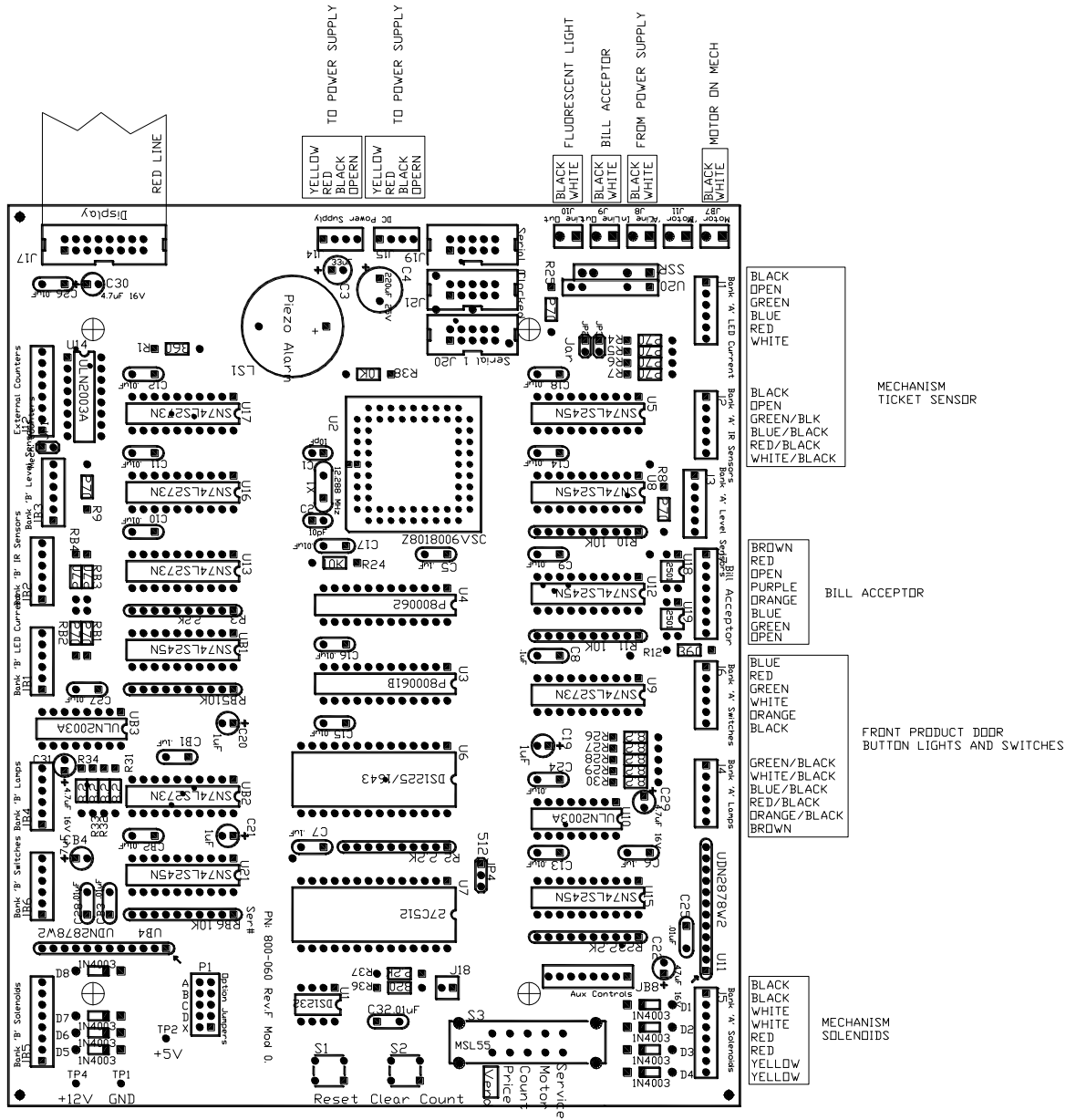

PYRAMID BILL ACCEPTOR

Acceptor Diagnostics

Use the Diagnostic Pushbutton on the side of the acceptor (toward the rear) as shown.

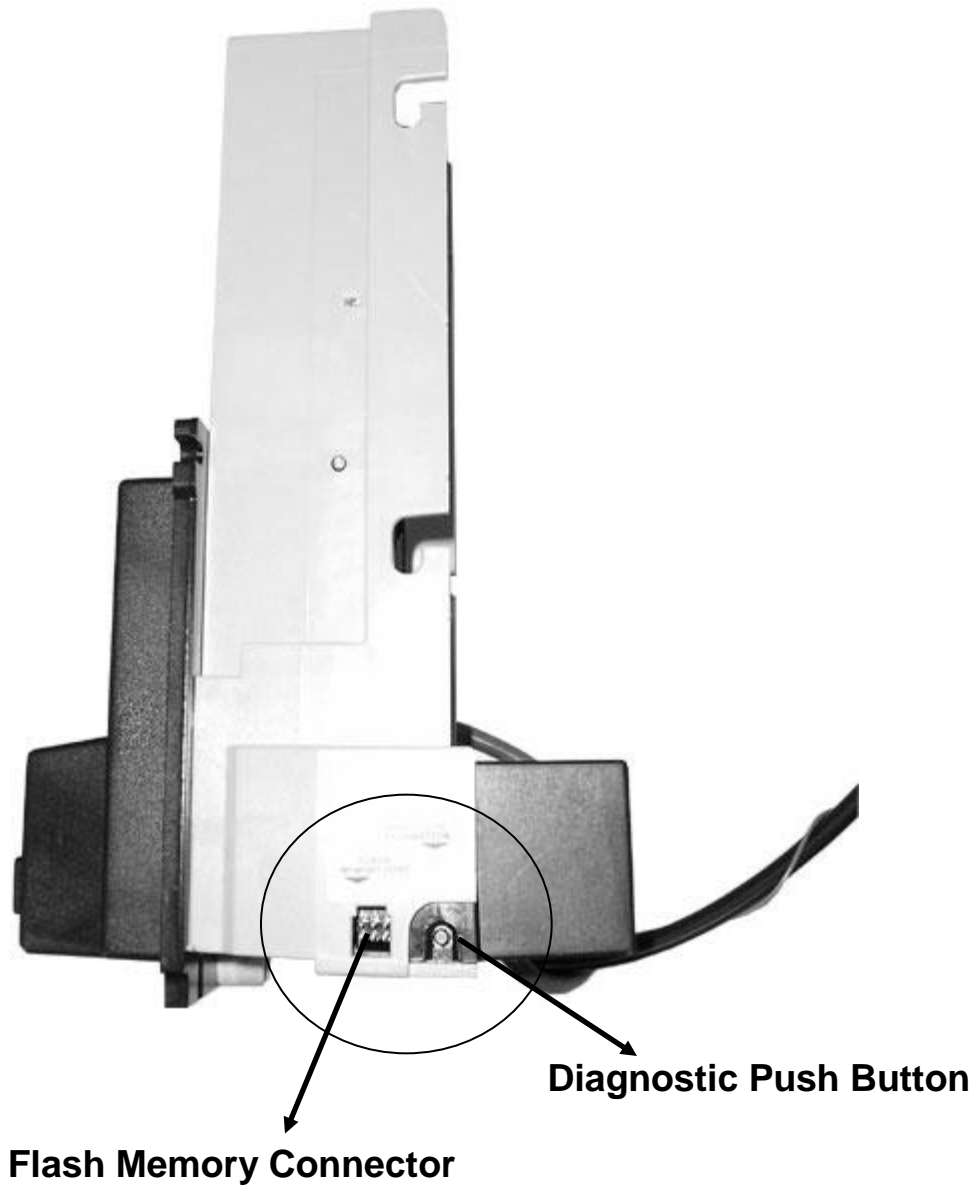

Front Bezel Lighting Flash Codes

The flash codes shown correspond to the Apex bill acceptor error. The acceptor will flash the error code, then wait 3 seconds and flash it again.

Flashing Code	Meaning of Flashing Code	Corrective Action
LED's always OFF	The acceptor has no power.	Check that power has been applied.
LED's always ON	No error exists – acceptor is OK.	None.
1 Flash	Something is in the bill path	Remove the cassette and Lower Sensor Plate to inspect for foreign objects. Clean if necessary.
2 Flashes	Something is obstructing the stacker.	Remove the cassette and Lower Sensor Plate to inspect for foreign objects. Clean if necessary.
3 Flashes	The cassette is full of currency.	Remove the cassette and empty it.
4 Flashes	The cassette has been removed	Replace the cassette.
5 Flashes	The acceptor is defective	Replace the acceptor.
6 Flashes	The acceptor is not enabled	Verify that the host has enabled the acceptor.
10 Flashes	Configuration Mode has been entered.	Configuration Card must be inserted into the acceptor or cycle power to the acceptor to exit this mode. See Configuration Section for details.

Removing the Cashbox

To remove the stacker, push back the Cashbox Latch toward the front of the acceptor. Then pull the Cashbox upward, and then pull back to remove.

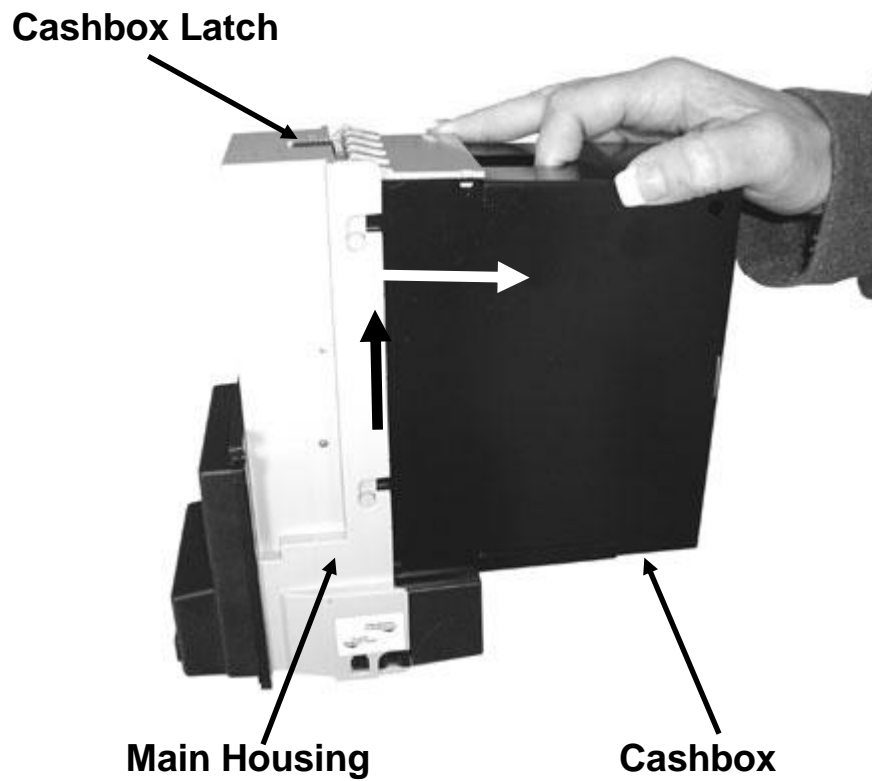

Installing the Cashbox

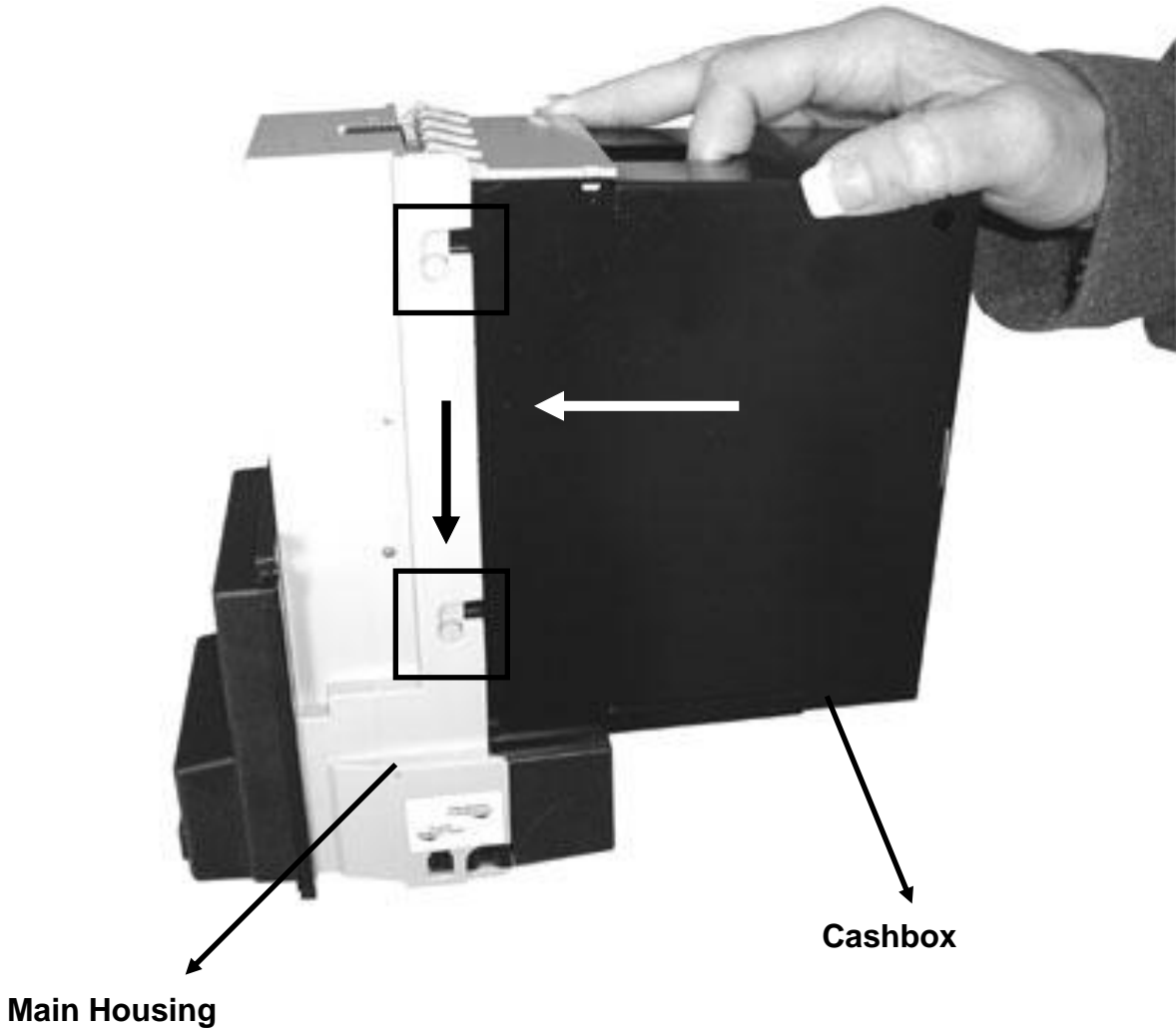

NOTE: WHEN INSTALLING THE CASHBOX MAKE SURE THE TABS ARE PUSHED FORWARD INTO THE SLOTS ON THE MAIN HOUSING AND THEN PUSH DOWN MAKING SURE THEY CLICK INTO PLACE. IF THE CASHBOX IS NOT PROPERLY INSTALLED THE BILL ACCEPTOR WILL NOT FUNCTION.

Removal of the Lower Sensor Plate

Removal of the Lower Sensor Plate is done by pressing the locking tab in and pulling the plate back. **NOTE:** Before removing the Lower Sensor Plate make sure you unplug the 18 pin connector from the other side of the bill acceptor. It is not shown in the picture.

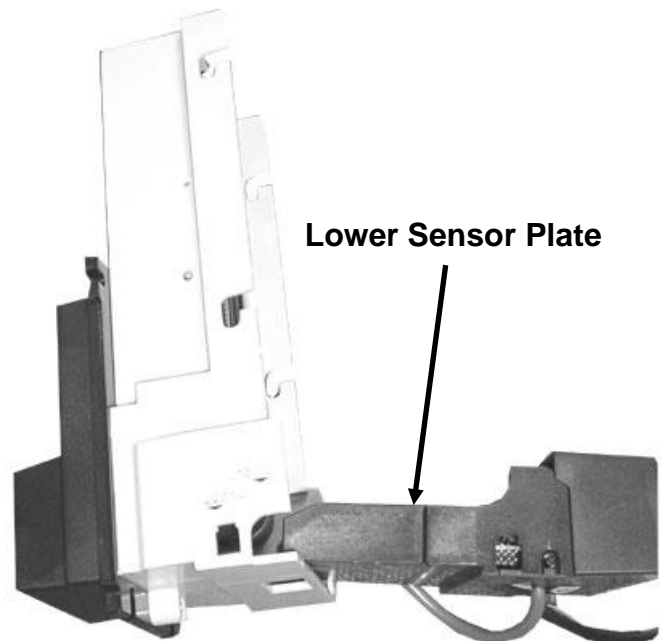
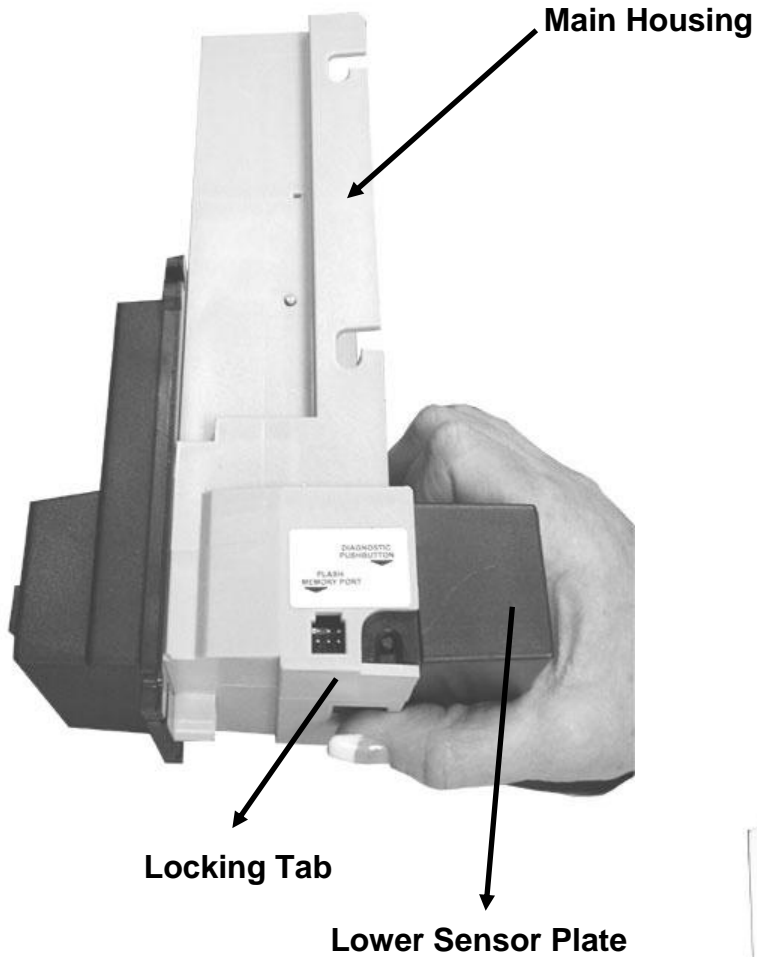

COIN MECHANISM (OPTIONAL)

If your dispensing machine is equipped with a coin mechanism, it is designed to work with QUARTERS ONLY and other currency should not be tried in it.

The coin mechanism is mounted to the faceplate with 4 small carriage bolts. If it is necessary to remove it, the nuts to these are removed with a 6mm nut driver or socket from the rear of the machine.

The electrical connections are 2 spade lugs at the rear of the mechanism. ONLY THE TOP 2 LUGS are used, the bottom terminal is not connected.

In the event of a jam that the release lever in front won't clear, open the bill acceptor door of the machine and turn the power to the machine off. Next, locate the cylindrical spring at the top of the mechanism and slide it toward you until it is only on about 1/2 inch.

As you look at the right side of the mechanism, you will see a metal collar with a screw rising from it. Grasp this with your thumb and forefinger and remove the right side of the mechanism.

At this point, the coins that are stuck will be exposed and should be gently removed with the use of a toothpick or other slim object.

Near the rear of the mechanism on the left, there is a brightly polished metal plate on a pivot. Immediately above this plate is a slot going into the mechanism. With a toothpick or other slim (not sharp) object, clear this area of any coins or foreign matter that may be stuck there.

Re-assemble mechanism by returning the side of the mechanism to its former position and sliding the cylindrical spring away from you until it is firmly holding the side plate to the rest of the mechanism.

If the mechanism fails to give credit for quarters inserted, check to see that both of the top 2 terminals are connected to the wiring harness. If they are, it will be necessary to adjust the bend on the trip wire located at the bottom rear of the mechanism. With a pair of needle nose pliers, just bend the wire a little more sharply at the same place it is already bent. This should cure the problem.

TECHNIK MFG., INC.
1005 17TH STREET
COLUMBUS, NE 68601
1-800-795-8251

SERVICE LOG SHEET

MACHINE SERIAL NUMBER _____ DATE INSTALLED _____
MACHINE MODEL TYPE _____ INSTALLED BY _____
BUSINESS LOCATION TYPE _____
BUSINESS ADDRESS _____
CITY/STATE/ZIP _____

<u>DATE</u>	<u>SERVICE PERFORMED</u>	<u>SERVICED BY</u>
_____	_____	_____
_____	_____	_____
_____	_____	_____
_____	_____	_____
_____	_____	_____
_____	_____	_____
_____	_____	_____
_____	_____	_____
_____	_____	_____
_____	_____	_____
_____	_____	_____
_____	_____	_____
_____	_____	_____
_____	_____	_____
_____	_____	_____
_____	_____	_____
_____	_____	_____
_____	_____	_____
_____	_____	_____
_____	_____	_____
_____	_____	_____
_____	_____	_____
_____	_____	_____
_____	_____	_____

MACHINE LOG SHEET

<u>DATE</u>	<u>MACHINE ROW</u>	<u>CARD VALUE</u>	<u>TOTAL CARDS</u>	<u>TOTAL CASH</u>
--------------------	---------------------------	--------------------------	---------------------------	--------------------------
