

THE MASTER 2

SET UP AND OPERATION MANUAL

TABLE OF CONTENTS

SAFETY	2
UNPACKING	2
MACHINE MOUNTING	3
MACHINE MOUNTING DIAGRAM	4
AUTOMATIC SEQUENCING	4
MODE OF OPERATION	5
INSTALLING PUSHBUTTONS	5
PRICING THE MACHINE	6
CARD THICKNESS ADJUSTMENT	6
LOADING/UNLOADING CARDS	7
SOLD OUT LAMPS	7
CHECKING THE COUNTS	7
MOTOR MODE / COUNTING FEATURE	8
INITIALIZING PROCEDURE	8
RESET PROCEDURE	8
TROUBLESHOOTING	
ERROR CODES	9
ERROR CODE FLOW CHARTS	10
CARDS JAM OR HESITATE	15
CARDS JAM OR HESITATE FLOW CHART	15
ODD COUNTS OR DISPENSING ERRORS	16
CARD NOT DISPENSING FLOW CHART	16
FUSE BLOWN	17
POWER INTERRUPTIONS	17
NO POWER FLOW CHART	17
CALLING A TECHNICIAN	18
SERIAL NUMBER LOCATION	18
REGULAR MAINTENANCE	18
PYRAMID BILL ACCEPTOR	19-23
TWO ROW CIRCUIT BOARD	24
SERVICE LOG SHEET	25
MACHINE LOG SHEET	26

SAFETY CONSIDERATIONS

1. Unplug the machine when servicing – failure to do this could cause serious injury.
2. If the power cord is damaged, the manufacturer, its service agent, or a similarly qualified person must replace it.
3. Permanent bypass of any safety switches may cause serious injury.
4. Refer to the “**Machine Mounting**” section of the manual for proper installation instructions.
5. A three prong grounded outlet must be used to power this machine.
6. Do not overload power circuits.
7. Do not use extension cords to run power to this machine.

UNPACKING

When the machine is received, it should be carefully unpacked and checked closely for any possible damage. If a freight company is involved and there is damage, please notify them immediately. They will need to thoroughly inspect the damage and fill out a report. Please **do not** install the machine until this has been done.

Please remove and save packing materials for later use.

The following items should be packed in the carton.

QUANTITY

DESCRIPTION

1	Pull Tab Vending Machine
1	3 AMP fuse
2	Short weights
2	Long weights with knobs
8	Pushbutton labels
4	Machine Keys (2 per door)
1	Hex wrench (side of mech)
1	Card Hook
4	Lag Bolts
1	Operation Manual

*If the machine is equipped with a modem, an alarm, or a printer an Options Manual will be included as well.

MACHINE MOUNTING

1. Tools needed
 - a. Electric drill
 - b. 1/4" drill bit
 - c. 1/8" drill bit
 - d. Rubber mallet or hammer
 - e. 1/4" nut driver or flathead screwdriver
 - f. Ratchet
 - g. 7/16" socket
 - h. 7/16" wrench
2. It is recommended to mount the base to the floor before mounting the cabinet to the base.
3. It is always recommended to mount the cabinet to the base assembly. Mounting to either the wall or to the floor is also recommended but it is not necessary to mount to both.

Decide whether you are going to mount the base to the floor or the cabinet to the wall.

1. Mounting the base assembly to the floor **without** the optional parts.
 - a. Drill four 1/4" holes 3/4" deep using the Anchor Hole Pattern on the previous page.
 - b. Hammer the four stud anchors into the holes that you drilled.
 - c. Place the base assembly on the 4 stud anchors.
 - d. Place a 1/4" washer and a 1/4 nut on each stud anchor and fasten securely.
2. Mounting the cabinet to the base assembly.
 - a. Run the power cord from the cabinet through the hole in the top of the base assembly.
 - b. Finish running the power cord out the bottom side hole of the base.
 - c. Place the cabinet on top of the base assembly.
 - d. Place a carriage bolt and a 5/16" washer into each hole.
 - e. Place a 1/4" washer and a 1/4-20 nut onto the carriage bolt.
3. Mounting the Cabinet and Base Assembly to the wall.
 - a. Having already done step B, drill four 1/8" holes in the wall using the Back Hole Pattern.
 - b. Insert a Hex Lag Screw and a 1/4" washer into the holes in the CM cabinet through into the wall.
 - c. Remember that the CM cabinet will be held more securely if the lag Screws are going into the studs in the wall.

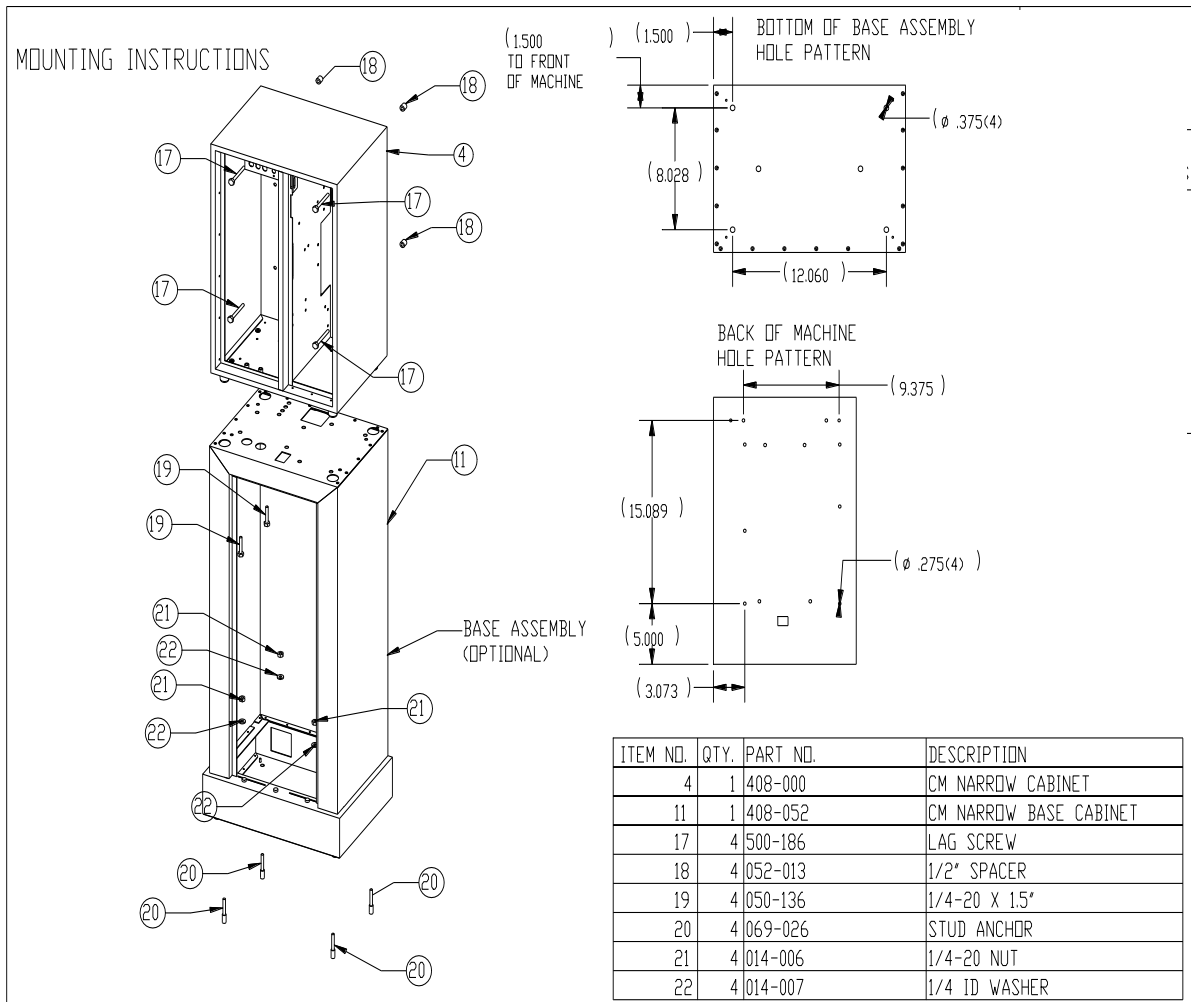

AUTOMATIC SEQUENCING

The power switch is located on the main control bar inside the dispensing side of machine. When the machine is first turned on, it will start its automatic sequencing. The sequence starts with three audio "beeps". The LCD will display important information (software version information, and the number of columns it has been initialized for). The machine will cycle each row's solenoid and pushbutton light at the same time. Each row should "lift" and each corresponding light should light. This automatic sequencing is to be used as an aid to ensure that the electronics and moving parts are working properly.

MODES OF OPERATION

As you are facing the front of the machine with the product door open, you will see the control bar in the dispensing side of the machine. The selector knob allows you to select either **VEND, PRICE, COUNT, MOTOR, OR SERVICE**.

To change modes of operation use the selector switch located on the control bar.

VEND MODE: This mode is what the machine should be in during normal operation.

PRICE MODE: This mode is used to price the individual columns.

COUNT MODE: This mode is used to check and clear accounting information.

MOTOR MODE: This mode is used to count inventory, clear a jammed card, adjust card thickness, and troubleshooting.

SERVICE MODE: This mode is used for assisting in troubleshooting and adjustments. All normal vend mode functions are available except money accepted and cards dispensed are not recorded into the accounting information. When in the service mode, the audible alarm will sound briefly every 15 seconds to serve as a reminder that you are in the service mode.

INSTALLING PUSHBUTTONS

The pushbutton assembly includes the clear top cap, the pushbutton label, the white plastic back, and the pushbutton itself. Insert the currency legend into the clear top cap so that when looking at the front of it, it reads correctly, not upside down. Place the white plastic back in next, and then simply snap in the actual pushbutton fixture. To remove the cover, use a thin screwdriver and pry it loose between the clear cap and the outer shell. Note the following illustration.

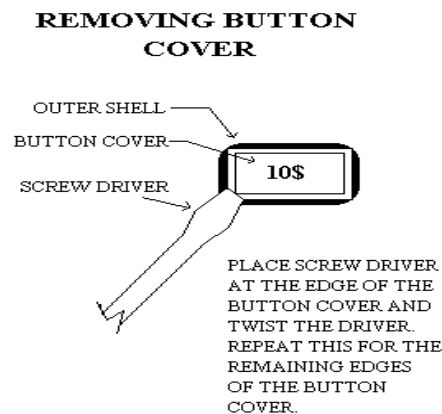
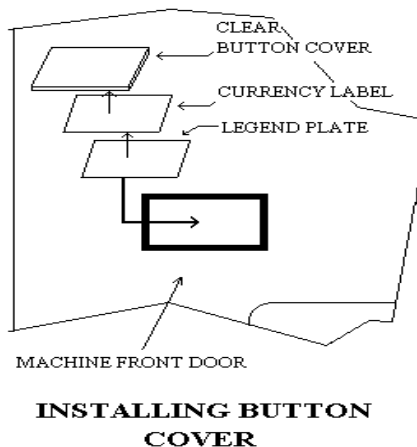

IMPORTANT: BE SURE TO GO THROUGH THE “**PRICING THE MACHINE**” SECTION OF THIS MANUAL AFTER CHANGING THE CURRENCY LABELS!!!

PRICING THE MACHINE

As you are facing the front of the machine with the product door open, you will see the control bar in the dispensing side of the machine. The selector knob allows you to select either **VEND, PRICE, COUNT, MOTOR, OR SERVICE.**

For the pricing mode, you must turn the selector knob to the “**PRICE**” position. Notice the display on the front of the machine is reading, “**Price column A**”. Below that a dollar amount is displayed. To change to the price of the card you are selling:

1. Press the column A pushbutton to select a desired price.
2. Press the “**SELECT**” (black) button to change rows and repeat step one.

Pricing is completed when the selector knob is in the “**VEND**” position. The machine is now ready to vend cards.

CARD THICKNESS ADJUSTMENT PROCEDURE

CARD ADJUSTMENT

1. With a hex head wrench, turn the adjustment screw on the dispensing mechanism counter-clockwise until a card will not pass the adjustment mechanism.
2. To make a “test card” place (2) pieces of clear tape or (1) piece of electrical tape as shown below.
3. Place a “test card”, tape first, in the bottom of the column you wish to adjust.

TEST CARD

4. Place the adjustment weight on top of the card
5. Add some money to the machine.

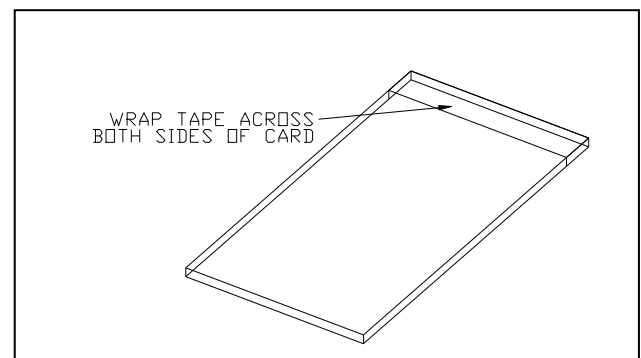

BEFORE GOING ANY FURTHER, READ THE INSTRUCTIONS BELOW!!!

6. Place the hex head wrench into the adjustment screw.
7. With the door open, dispense a card. But at the same time you are dispensing a card, turn the adjustment screw clockwise until a card is dispensed. It may take a few tries before a card is dispensed. Remember, to run the motor you must temporarily bypass the door open switch.
8. Once a card is dispensed, the column is properly adjusted.
9. Follow the procedure on the other columns.

LOADING / UNLOADING CARDS

You are now ready to start loading your cards. Once the cards are in the rows, place a weight on top of the stack. **When using the long weights, make sure the knob is toward the front of the mechanism.**

In “**SERVICE**” mode, insert coins in the coin acceptor to make sure the correct number of cards are dispensed and the mechanism is functioning properly.

For unloading cards, a card hook is provided that allows for easy removal of the bottom-most cards.

SOLD OUT LAMPS

The vending machine has the following features so that it may be easier to determine “sold out” conditions and remaining inventory cycle count.

The “sold out” light will indicate either the column is out of cards or a dispensing problem has occurred.

- If the “**sold out**” light is on **solid**-the column is out of cards
- If the “**sold out**” light is **blinking**- a card was not dispensed when the column was selected.

CHECKING THE COUNTS

The vending machine has “**re-settable**” and “**non re-settable**” accounting information. When the select knob is on “**COUNT**”, this information can be viewed on the display on the front of the machine.

The “**SELECT**” or “**NEXT**” button is used to view the counts for cash and cards. The “**SELECT**” or “**NEXT**” button will go through all the information of total and period counts. The cash and cards titled “**PERIOD**” are **re-settable counts**. The re-settable counts can be cleared by pressing the “**CLEAR**” or “**SET**” button. The cash and cards titled “**TOTAL**” are non re-settable. The non-resettable counts will keep lifetime total until the machine is re-initialized.

Returning the selector knob to “**VEND**” will set the machine to normal operations.

MOTOR MODE / COUNTING FEATURE

For inventory purposes, the machine will electronically count the remaining cards in each column.

- Place the selector knob in the “**MOTOR**” position. The motor will run constantly.
NOTE: The product door must be open, and the “**motor kill switch**” must be bypassed. This is done by taking the brown cap off of the on/off switch and inserting it into the slot, directly to the left. The motor will constantly run when this cap is in the slot.
- To count the remaining cards in a column, press the pushbutton for that column. The machine will then dispense the cards from that column. The machine will count each card dispensed.
- To stop the column from dispensing before empty, press the push button for that row for one second. Note that the cards will stop dispensing, and the count on the credit display will indicate the number of cards dispensed. This count will reset to zero when the pushbutton is pressed again.

INITIALIZING PROCEDURE

This procedure allows automatic reprogramming of the entire system. All pricing and re-settable counts will be lost.

This procedure is as follows:

1. Position the selector knob to the “**PRICE**” position.
2. Hold down the “**CLEAR**” button
3. Turn the machine off and back on.
4. Wait for the audible signals (beeps)
5. Release the “**CLEAR**” button

RESET PROCEDURE

If this machine malfunctions, it will automatically shut down. Once a card jam is cleared, the machine must be reset. Simply move the power switch to the off position for about 3 seconds, and then back on. The machine is reset. The machine has a battery back up for memory; so shutting the power off and on again does not cause the machine to lose its count or program.

TROUBLESHOOTING

WARNING!!!! WARNING!!!! WARNING!!!! WARNING!!!! WARNING!!!!
ALWAYS UNPLUG THE MACHINE PRIOR TO
SERVICING THE MACHINE

ERROR CODES

Diagnostic flow charts follow for each error code

The machine has the ability to determine its own reason for not functioning. It has several error codes that tell you where the problem is occurring. The codes will appear on the display, located on the cash door. The codes that may be encountered are as follows:

- E-04** This means that a power interruption occurred while a card was being dispensed. To clear this error code, push the “**CLEAR**” or “**SET**” button on the control bar with the power on.
- E-10** This means that the machine has lost its memory, the row denominations will default to the default pricing and the counts will be cleared. This indicates the machine needs to be re-initialized – see the “**Initializing Procedure**” section of this manual.
- E-13** This means the selected ticket took too long to dispense. Remove the ticket from that row. To clear, turn the machine off, and then back on.
- E-14** This means that an unexpected card or foreign object was sensed. Physically remove the card or foreign object. To easily remove a card turn the selector switch to the motor position (the door open switch must be bypassed).
If **E-14** error codes are frequent, then, with the selector knob in “**VEND**”, press the “**CLEAR**” or “**SET**” button. The pushbutton light will indicate the column that is causing the error code. When a column’s pushbutton light is lit, this is the column that may have a bad sensor. **Contact a service technician.**
- E-15** This means the non re-settable counters are corrupt. The non re-settable counts have cleared to zero. Press the “**CLEAR**” or “**SET**” button on the control bar to clear this code. Please note that other error codes may occur after clearing the **E-15**, (usually **E-04**).

ERROR CODES FLOW CHART

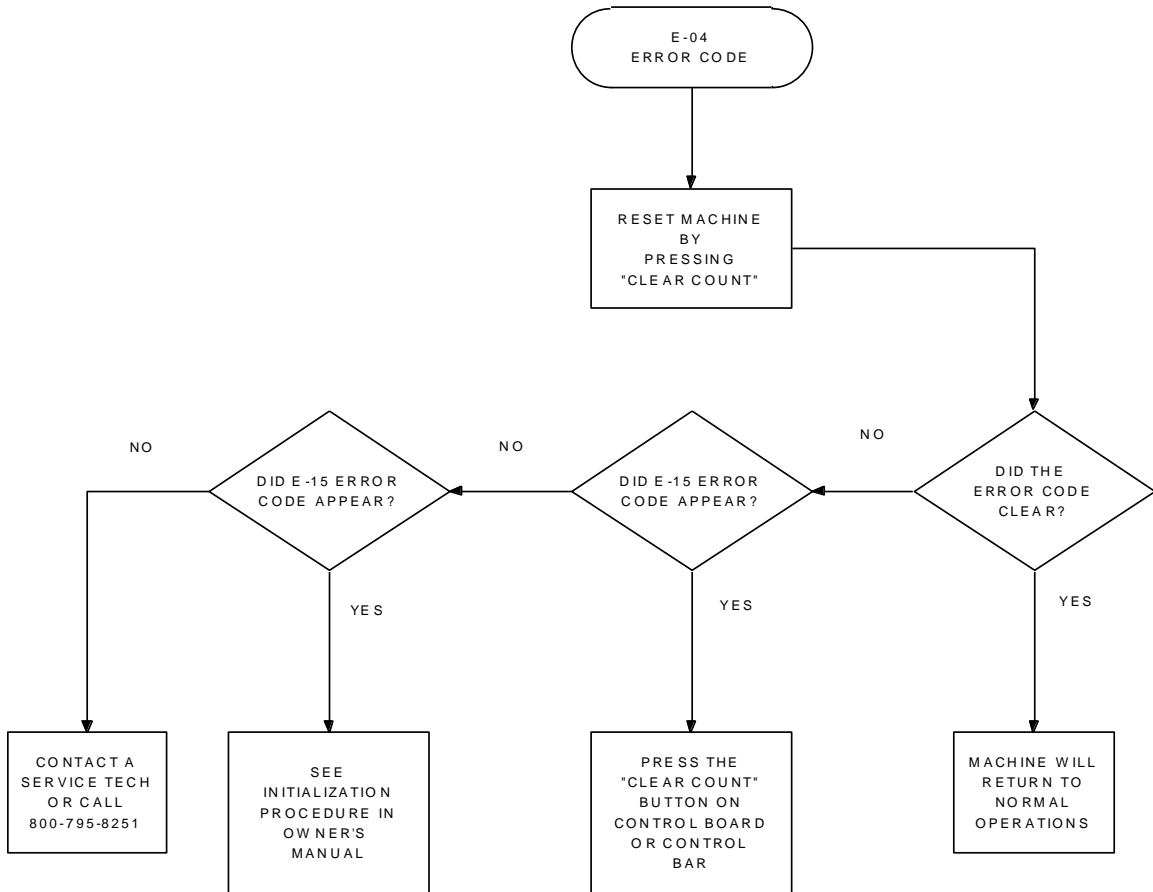

ERROR CODES FLOW CHART

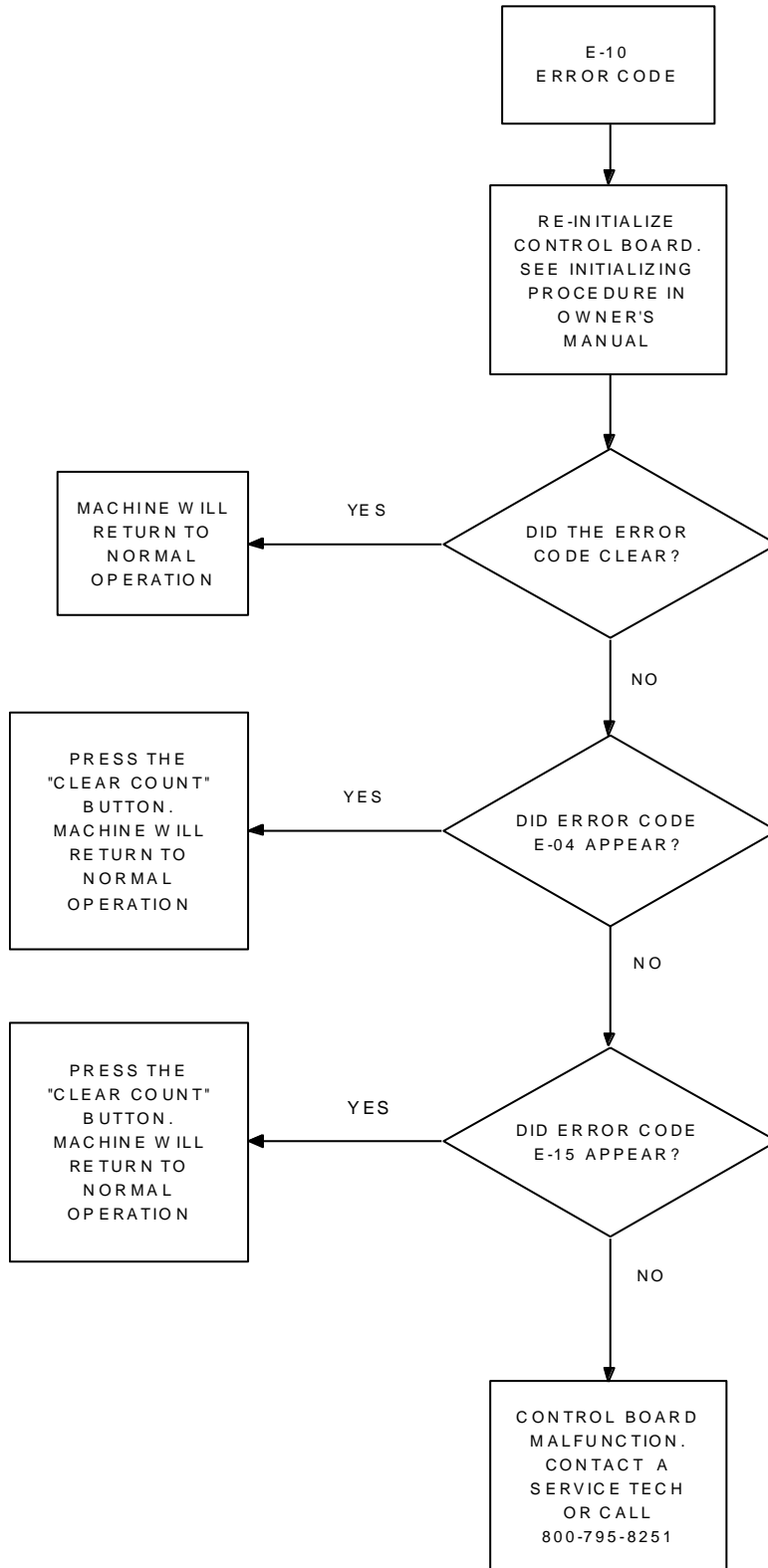

ERROR CODES FLOW CHART

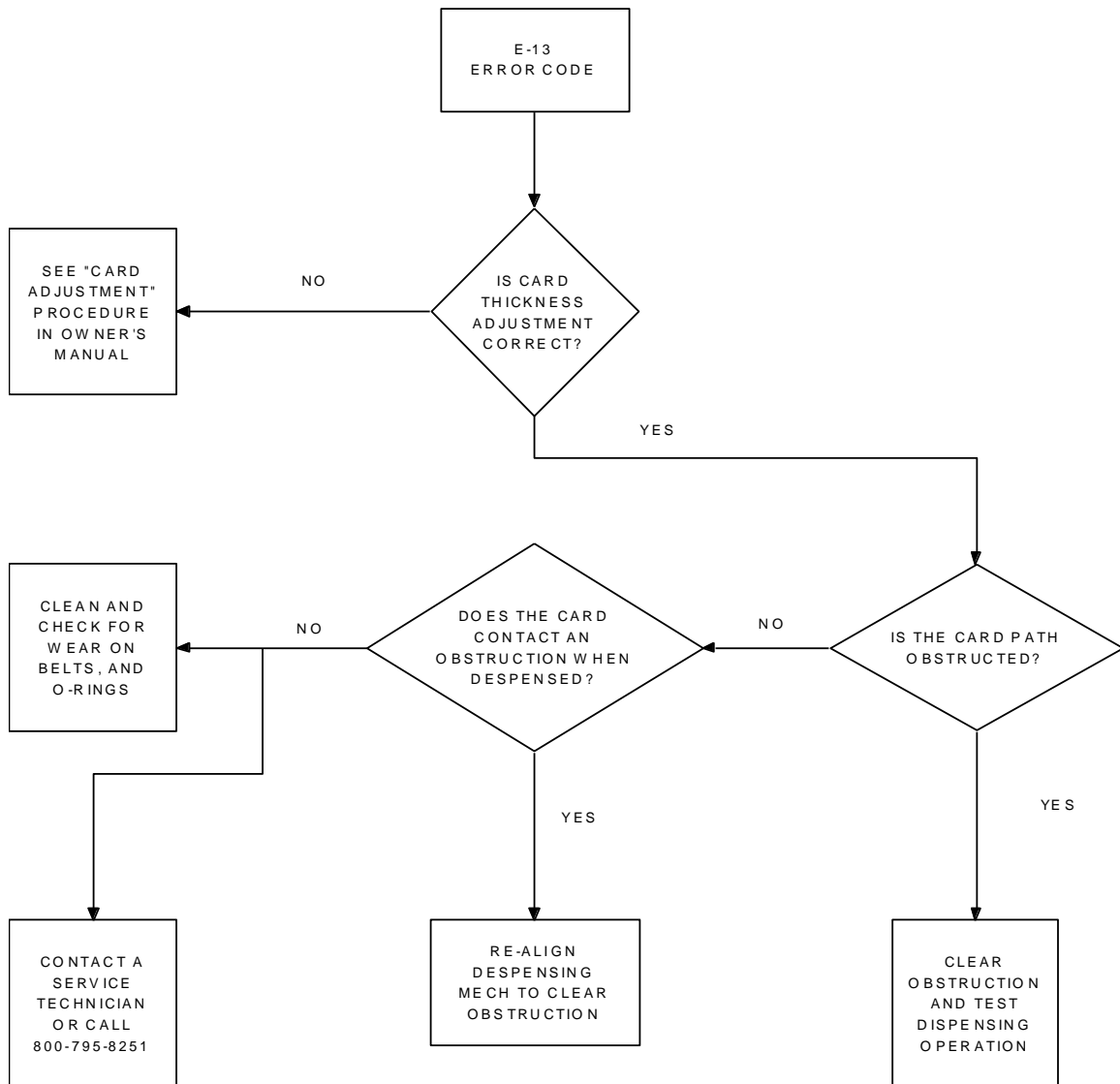

ERROR CODES FLOW CHART

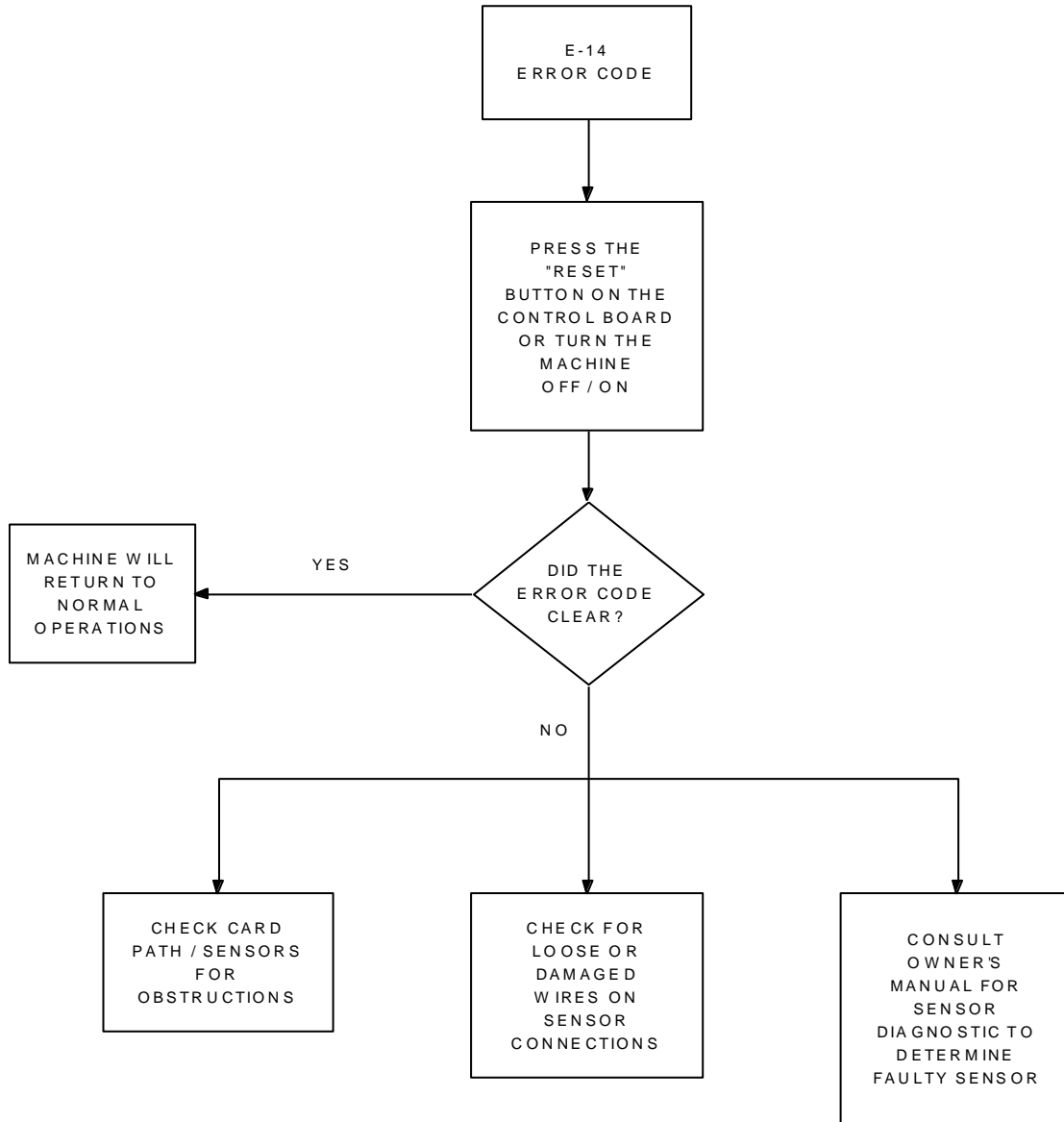

ERROR CODES FLOW CHART

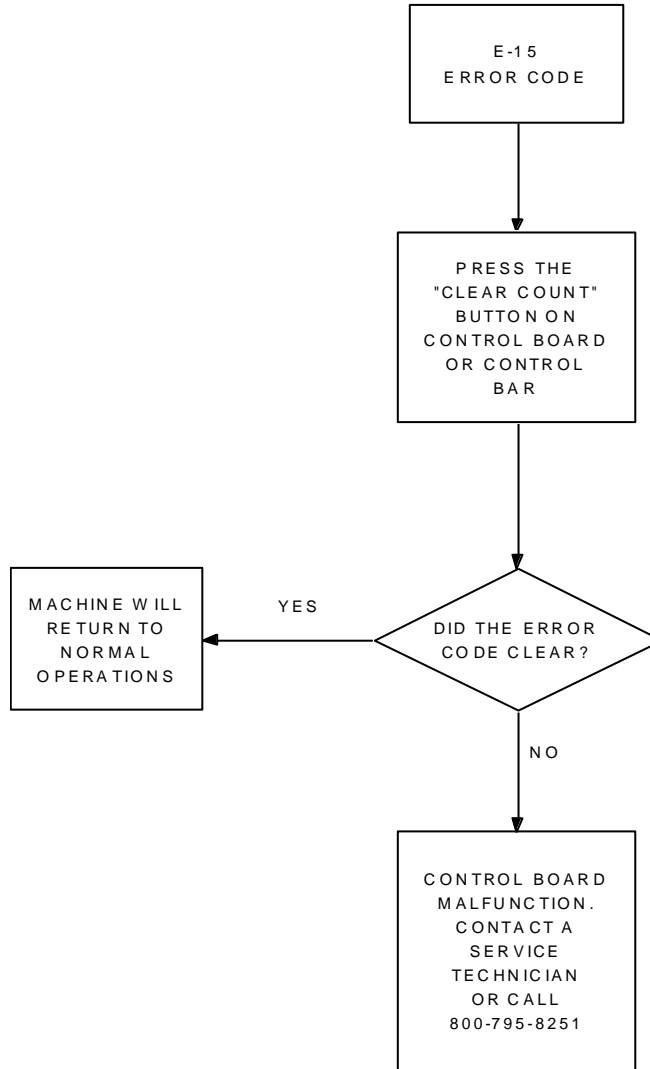

CARDS JAM OR HESITATE DURING DISPENSING

1. Cards may be too thick or too thin. See “**Card Thickness Adjustment Procedure**” section of this manual.
2. Cards may be damaged. Remove damaged card and try again.

CARDS JAMMING OR HESITATING FLOW CHART

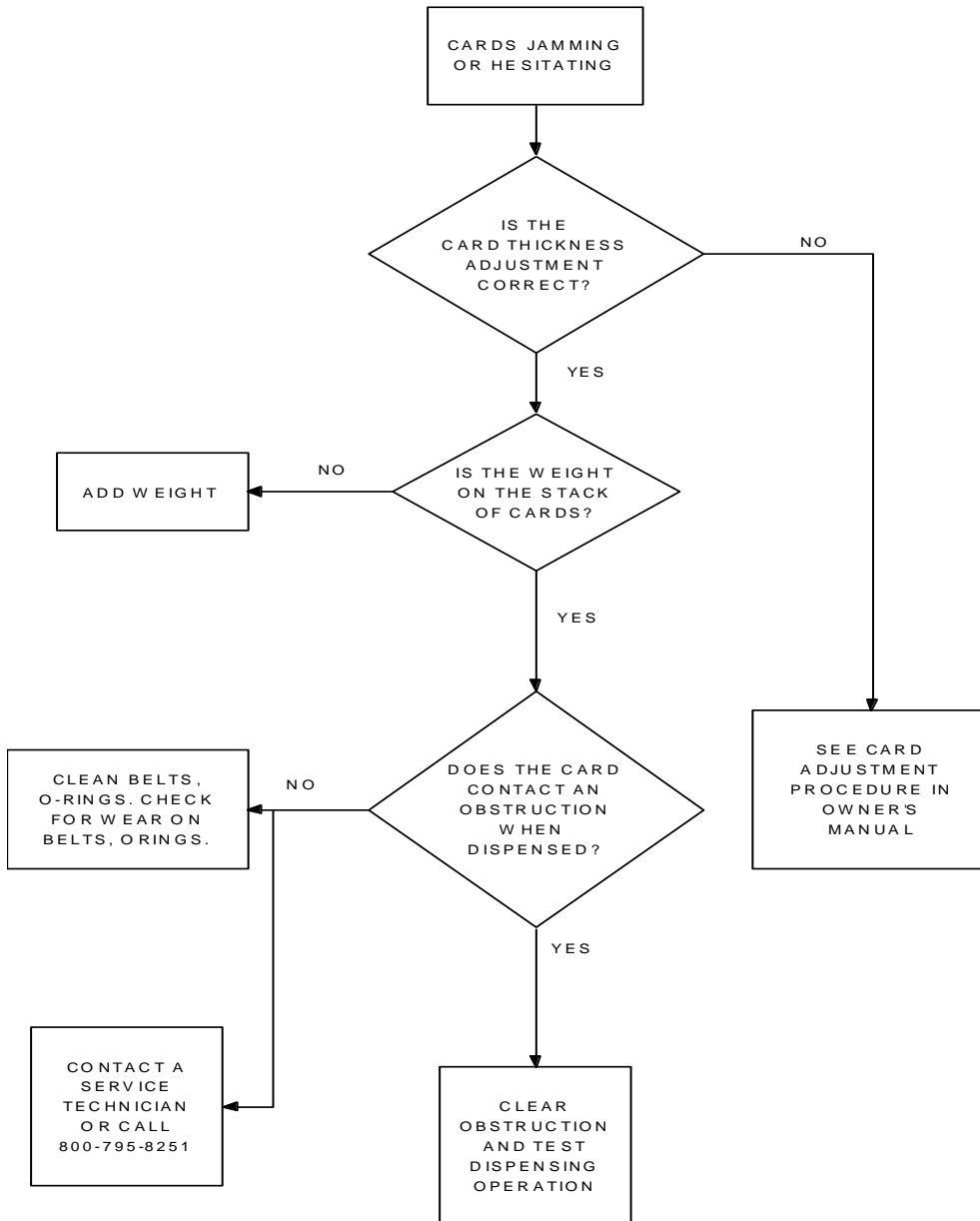

ODD COUNTS OR DISPENSING ERRORS

1. Static electricity is a major contributor to this and all other electronic equipment. You must use a 3-prong receptacle.
2. At times, usually in the winter, static problems can occur. The carpet around the machine may need sprayed with a diluted mix (10:1) of Downy softener and water (once every two weeks.) **DO NOT SPRAY MACHINE.**
3. Low voltage causes many electronic problems. If your unit is plugged into an extension cord, or is on the same line with refrigeration equipment, etc., the 220-volt supply may be less than 200 volts. Have an electrician check the voltage supplied to the machine and repair as needed.
4. The sensors may be dirty. The sensors are located along side the drive wheels. Should this sensor get filled with debris, it may not be able to function. Simply blow air on it, or use a cotton swab to clean this area.
5. Total re-programming may be needed. See the **"INITIALIZING"** procedure. This procedure erases all settings and re-settable counts. The machine must now be re-programmed.

CARDS NOT DISPENSING

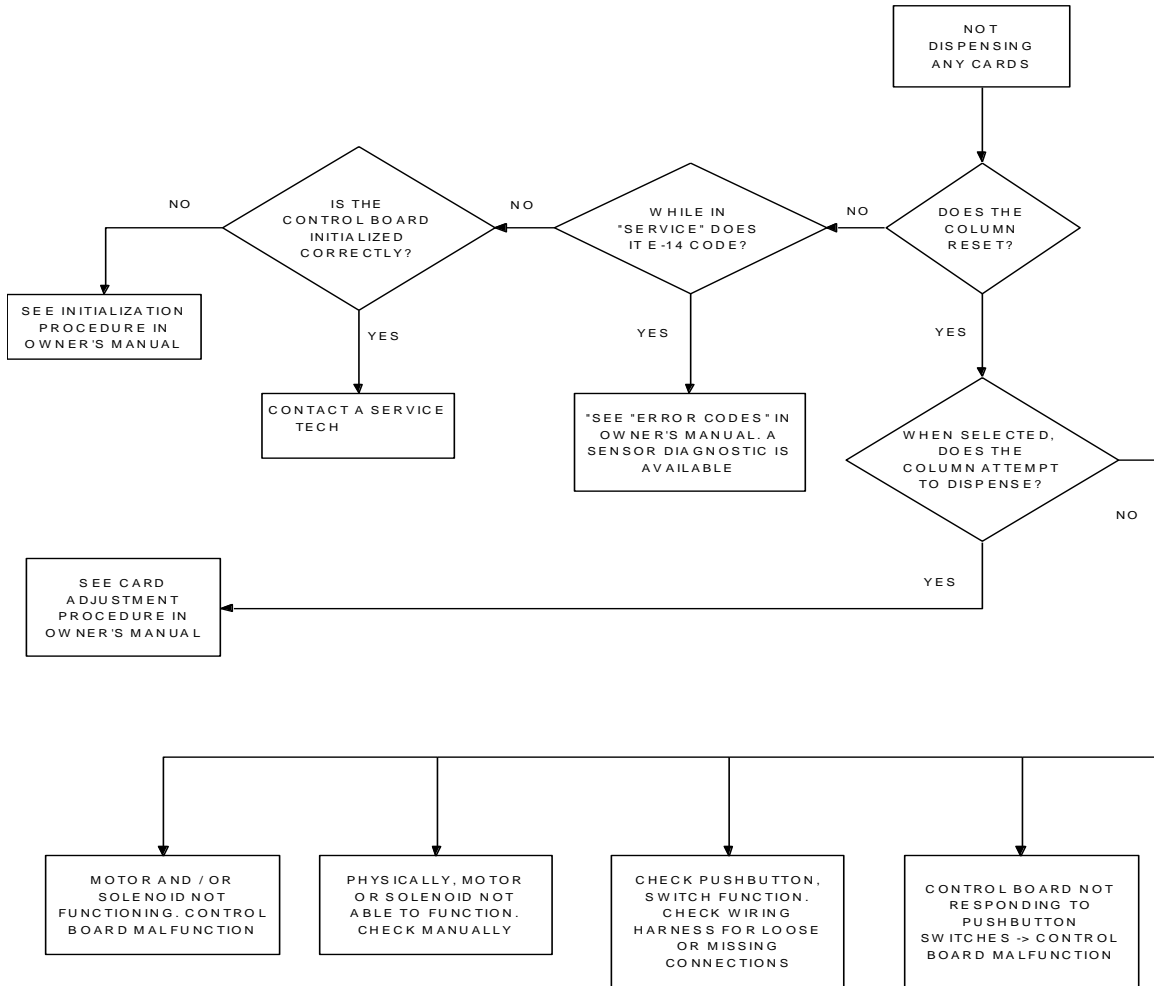

FUSE BLOWN

If the machine shuts down and nothing works, check the fuse. The machine uses a 3 AMP fuse.

POWER INTERRUPTION

It is possible that if the power dies at the same moment a card is being dispensed, the card will stop and not be dispensed. The machine recognizes this situation by displaying an **E-04** error code. The machine will not operate until reset. The single card that was dispensed will not be counted in the money or card count. To correct counts if they are off, the owner of the machine can dispense one additional card and return it to the stack.

NO POWER FLOW CHART

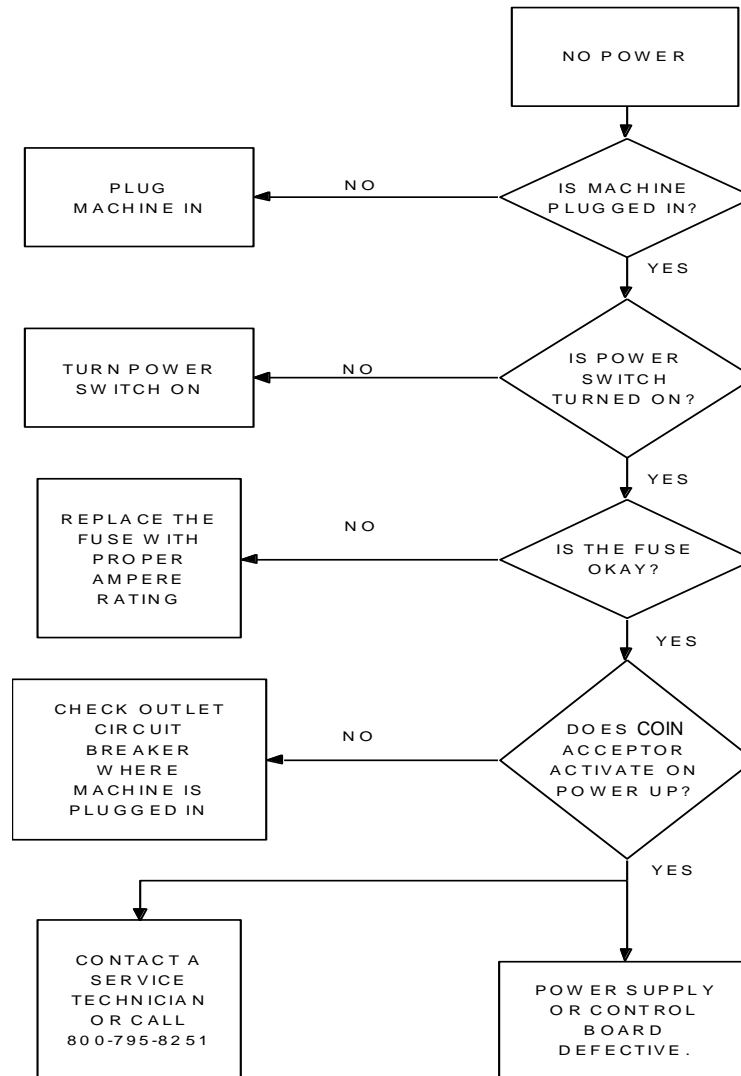

CALLING A SERVICE TECHNICIAN

Service is available at your fingertips. Simply call the number shown on the front of this manual or on the label placed on the inside of your machine.

WHEN CALLING FOR SERVICE, PLEASE HAVE YOUR MACHINE SERIAL NUMBER READY.

SERIAL NUMBER LOCATION

The machine serial number is located in three different places. Inside the front of door of the machine, on the inner left side of the cabinet and on the front of this manual.

REGULAR MAINTENANCE

Cleaning windows:

This should be done with care. Use a soft cloth with plastic cleaner. **Do not use a dry towel of any type**, this will leave scratches on the machine.

Machine Lubrication:

This should not be necessary. Improper lubrication can result in machine malfunction.

PYRAMID BILL ACCEPTOR

Acceptor Diagnostics

Use the Diagnostic Pushbutton on the side of the acceptor (toward the rear) as shown.

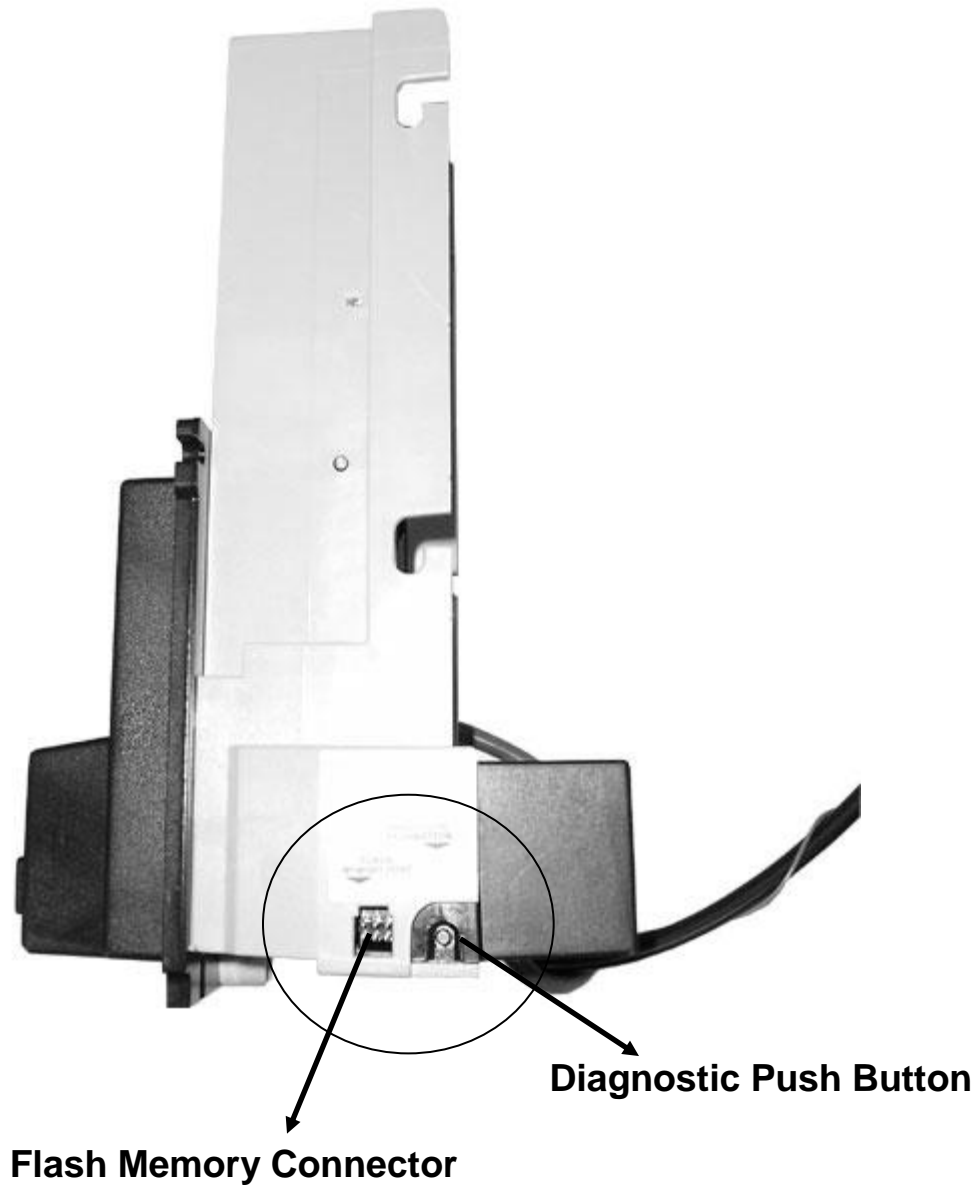

Front Bezel Lighting Flash Codes

The flash codes shown correspond to the Apex bill acceptor error. The acceptor will flash the error code, then wait 3 seconds and flash it again.

Flashing Code	Meaning of Flashing Code	Corrective Action
LED's always OFF	The acceptor has no power.	Check that power has been applied.
LED's always ON	No error exists – acceptor is OK.	None.
1 Flash	Something is in the bill path	Remove the cassette and Lower Sensor Plate to inspect for foreign objects. Clean if necessary.
2 Flashes	Something is obstructing the stacker.	Remove the cassette and Lower Sensor Plate to inspect for foreign objects. Clean if necessary.
3 Flashes	The cassette is full of currency.	Remove the cassette and empty it.
4 Flashes	The cassette has been removed	Replace the cassette.
5 Flashes	The acceptor is defective	Replace the acceptor.
6 Flashes	The acceptor is not enabled	Verify that the host has enabled the acceptor.
10 Flashes	Configuration Mode has been entered.	Configuration Card must be inserted into the acceptor or cycle power to the acceptor to exit this mode. See Configuration Section for details.

Removing the Cashbox

To remove the stacker, push back the Cashbox Latch toward the front of the acceptor. Then pull the Cashbox upward, and then pull back to remove.

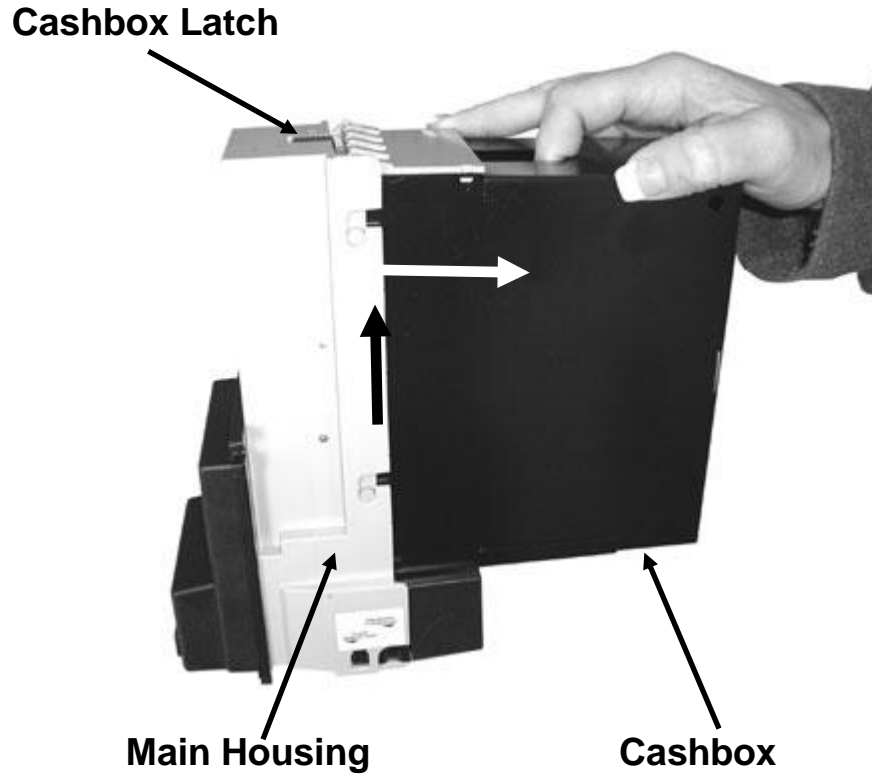

Installing the Cashbox

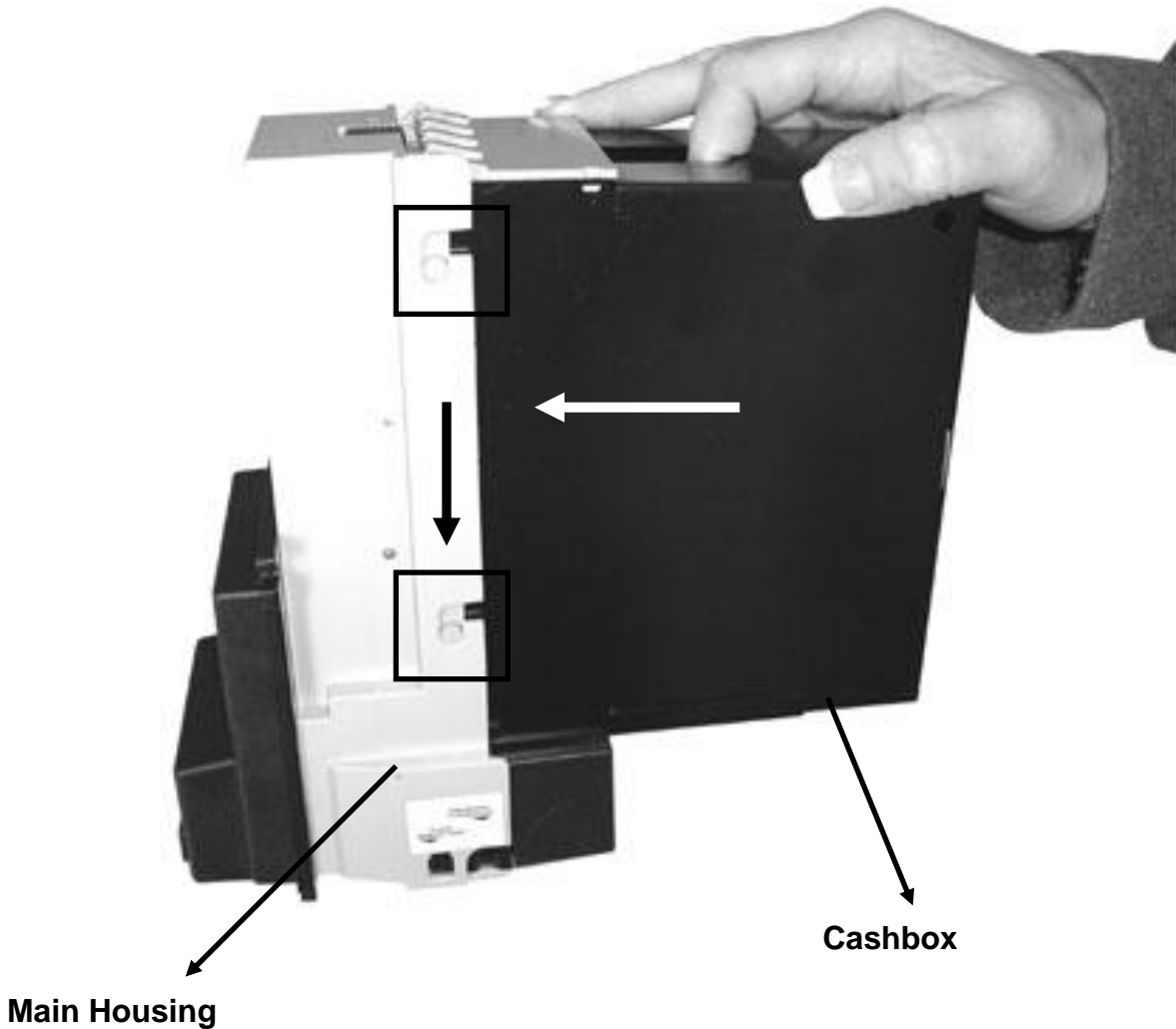

NOTE: WHEN INSTALLING THE CASHBOX MAKE SURE THE TABS ARE PUSHED FORWARD INTO THE SLOTS ON THE MAIN HOUSING AND THEN PUSH DOWN MAKING SURE THEY CLICK INTO PLACE. IF THE CASHBOX IS NOT PROPERLY INSTALLED THE BILL ACCEPTOR WILL NOT FUNCTION.

Removal of the Lower Sensor Plate

Removal of the Lower Sensor Plate is done by pressing the locking tab in and pulling the plate back. **NOTE:** Before removing the Lower Sensor Plate make sure you unplug the 18 pin connector from the other side of the bill acceptor. It is not shown in the picture.

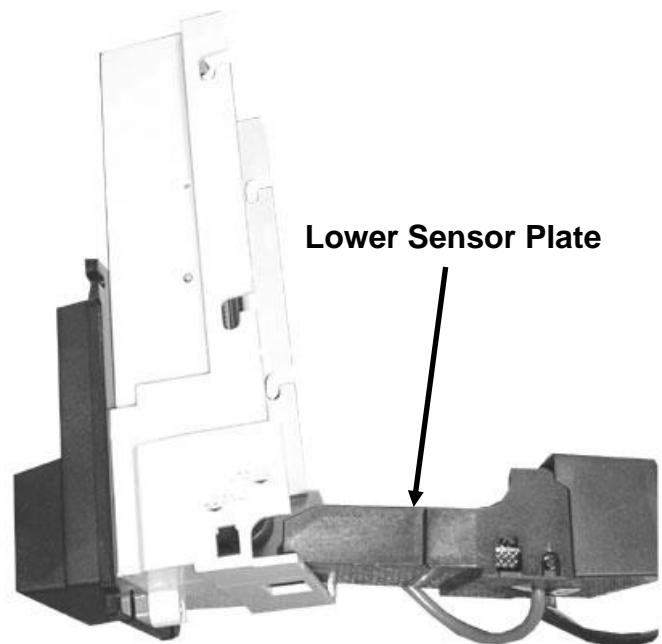
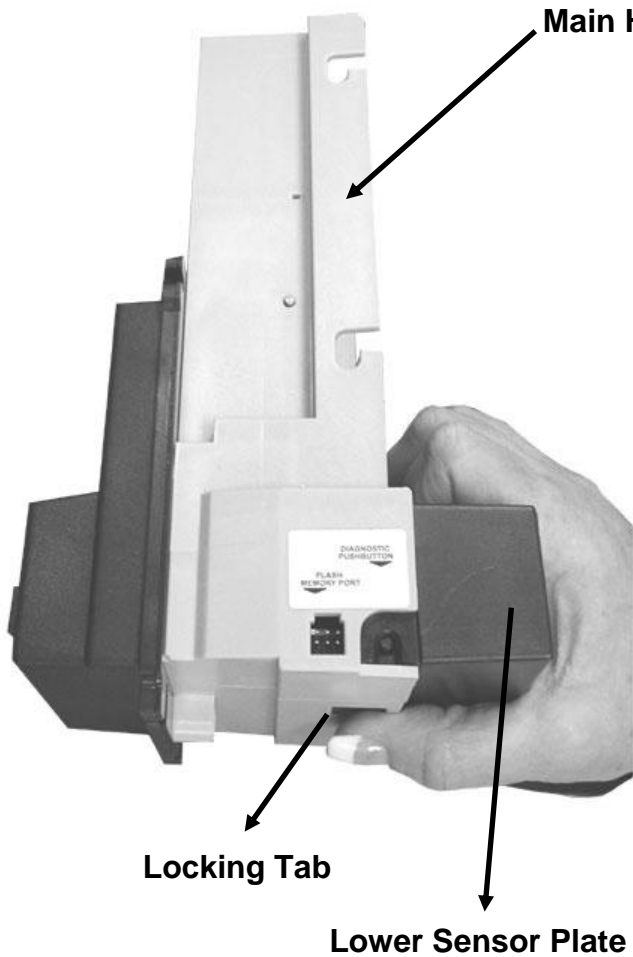

2-ROW CONTROL BOARD

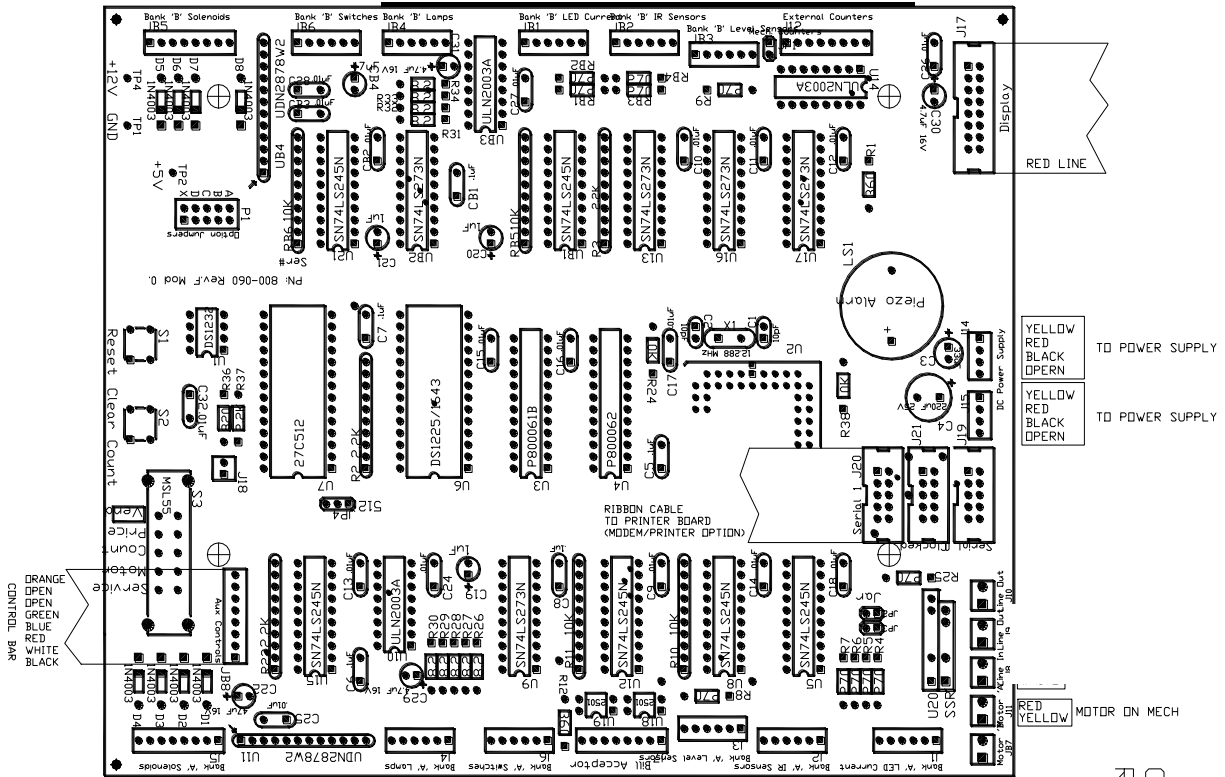

ORANGE
OPEN
GREEN
BLUE
RED
WHITE
BLACK
CONTROL BAR

- BLACK
 - RED
 - WHITE
 - OPEN
- MECHANISM
CARD SENSOR
- BLACK
 - RED/BLACK
 - WHITE/BLACK
 - OPEN
- MECHANISM
SOLD OUT SWITCHES
- BLACK
 - RED
 - GREEN
 - WHITE
 - OPEN
- MECHANISM
SOLD OUT SWITCHES
- BRT
 - DEE
 - DR4
 - GRE
 - DPE
- FRONT PRODUCT DOOR
BUTTON LIGHTS AND SWITCHES
- OPEN
 - GREEN
 - WHITE
 - BLACK
 - OPEN
 - BROWN
- MECHANISM
SOLENOIDS
- BLACK
 - WHITE
 - OPEN
 - OPEN
 - OPEN
 - OPEN
- MECHANISM
SOLENOIDS

C1
REVISION F BOARD LAYOUT

<p>TECHNIX MFG. INC. COLUMBIAS, NEBRASKA</p>	
NAME:	CM4
REV:	F CNTRL BRD
PART #:	---
DATE:	11/7/00
REV #:	A
SHEET:	1 OF
SCALE:	NONE
DRW'N BY:	KEC
CHK'D BY:	
APP'D BY:	
FILE #:	CM4 REV F
MATL:	
FINISH:	

